

Quarrix®

DOUBLE ROMAN COMPOSITE ROOFING

INSTALLATION MANUAL

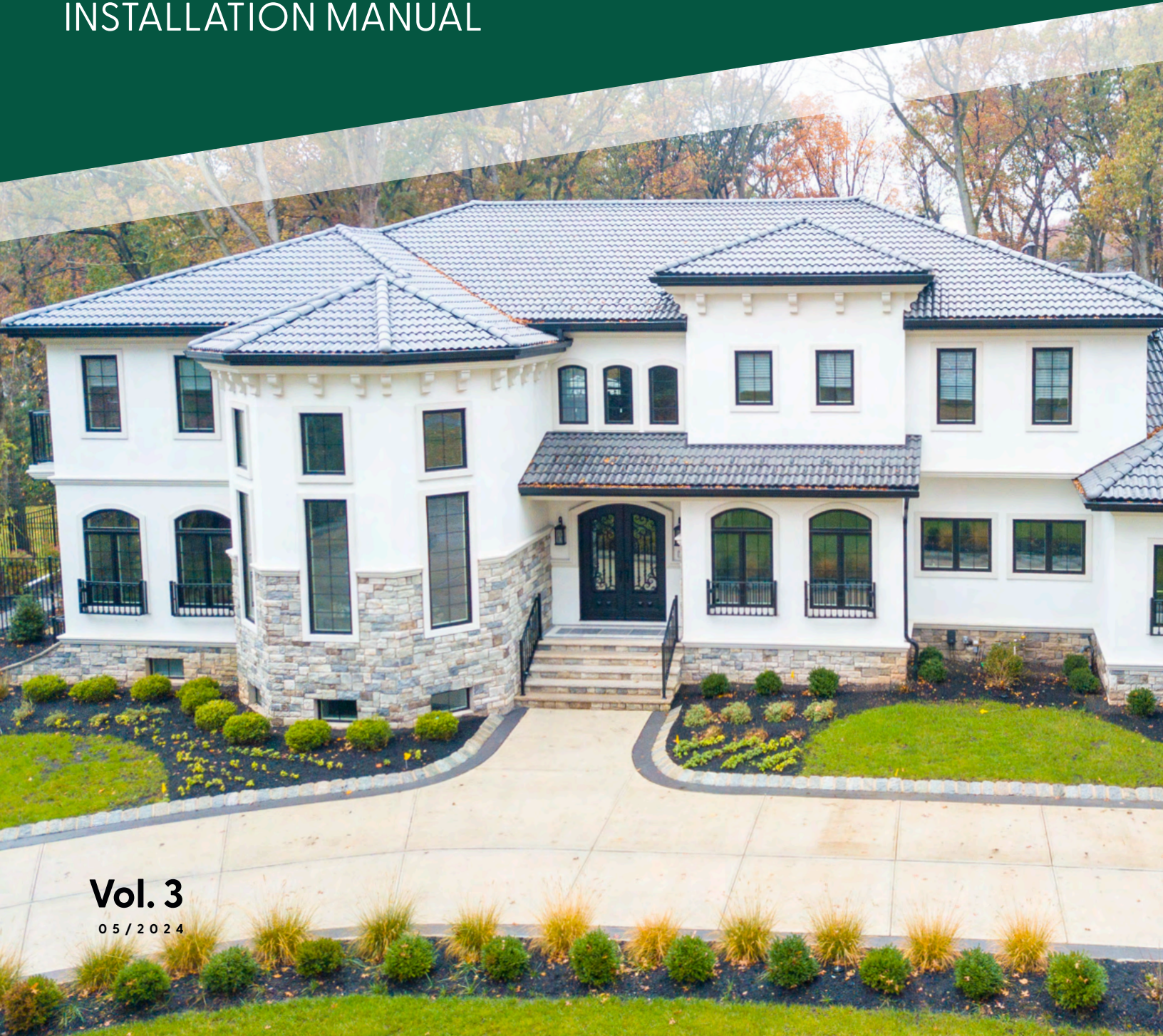

Vol. 3

05 / 2024

TABLE OF CONTENTS

Forward	4
Certification & Testing	4
Quarrix System Advantage	5
Quarrix Tile System Characteristics	6
Specialty Tools to Make the Job Easier	8
Installation Tips and Always/Never Guide	9
Before Getting Started	10
Getting Started	11
Installation at a Glance	16
Preparing Deck	17
Nailers	17
Flashings & Penetrations	17
Exposure & Battens	17
Batten Installation	19
Roof Loading	19
Lower Metal Eave Closures	19
Field Tile Installation	20
Upper Metal Closures	20
Weather Blocking	20
Hip Installation	21
Ridge Installation	21
Rake Installation	21
General Maintenance	22
Repair	22
Appendix	24
Tile System Metric Measurements	28
Warranty	29

DOUBLE ROMAN COMPOSITE ROOF TILE

Quarrix Double Roman Composite Roof Tile is a premium composite roofing product that will provide years of service and beauty to your structure, provided it is correctly installed. This installation manual will outline methods and practices for installing this tile profile in the most common situations. Tile installation details not covered in this guide, can be found in the Tile Roofing Institutes General Installation Manual provided by TRI/WSRCA. We recommend the TRI manual for additional reference and install support because most of the principles and practices for installing composite tile are similar to conventional clay or concrete tile installs. The Tile Roof Institute is a certified and nationally-recognized authoritative voice in the roofing community for tile roof installation and training.

Reading this manual and paying particular attention to the Always/Never guide sheet on page 9 in the Quarrix Installation Manual will provide the basis for a beautiful and leak-proof roof for decades to come.

Our Double Roman Composite Roof Tile is currently offered in six colors. It is possible to blend colors to achieve different aesthetics. The exact color selections and patterns are left to the installer to complement the roof design. We do not provide planograms for blended roofs.

READ THIS MANUAL COMPLETELY PRIOR TO BEGINNING THE INSTALLATION OF ANY QUARRIX DOUBLE ROMAN COMPOSITE ROOF TILE.

ALWAYS INSPECT EACH AND EVERY TILE AND ALL ACCESSORIES BEFORE INSTALLATION. NEVER INSTALL ANY PRODUCT IF ITS QUALITY IS IN QUESTION. NOTIFY QUARRIX IMMEDIATELY IF ANY PRODUCT IS BELIEVED TO BE DAMAGED.

CERTIFICATION & TESTING

Double Roman Composite Roof Tile was tested for the following ICC-ES per AC-07 Acceptance Criteria for Special Roofing Systems:

ASTM G155 – 2000 Hours – Xenon Weathering

ASTM D638 – Tensile

ASTM D638 – Tensile – Weathered

TAS 100 Wind Driven Rain Resistance

TAS 125 Uplift Resistance

TAS 102 Static Uplift Resistance

Penetration

ASTM E108 – Class A and C Fire

ASTM D1929 – Ignition Temps

ASTM D1929 – Ignition Temps – Weathered

ASTM D635 – Rate of Burn

ASTM D635 – Rate of Burn – Weathered

ASTM D2843 – Smoke Density Temperature Cycling

FM 4473 – Ice Hail Impact – Hail impact test for Class 4 Hail

*Submitted but not currently Florida or Miami Dade Approved.

QUARRIX COMPOSITE ROOF COMPONENTS

At Quarrix, we believe beautiful homes begin with beautiful roofs. And Quarrix composite tile roofs stay beautiful longer when they are properly installed using our complete system of tile components. Our system begins before the first tile is laid. It provides the foundational support tile roofs need and is engineered to protect against aging and fail points caused by water drainage, poor air-circulation, mortar joints and challenging roof angles. Quarrix tile components provide long-term superior performance for your peace of mind.

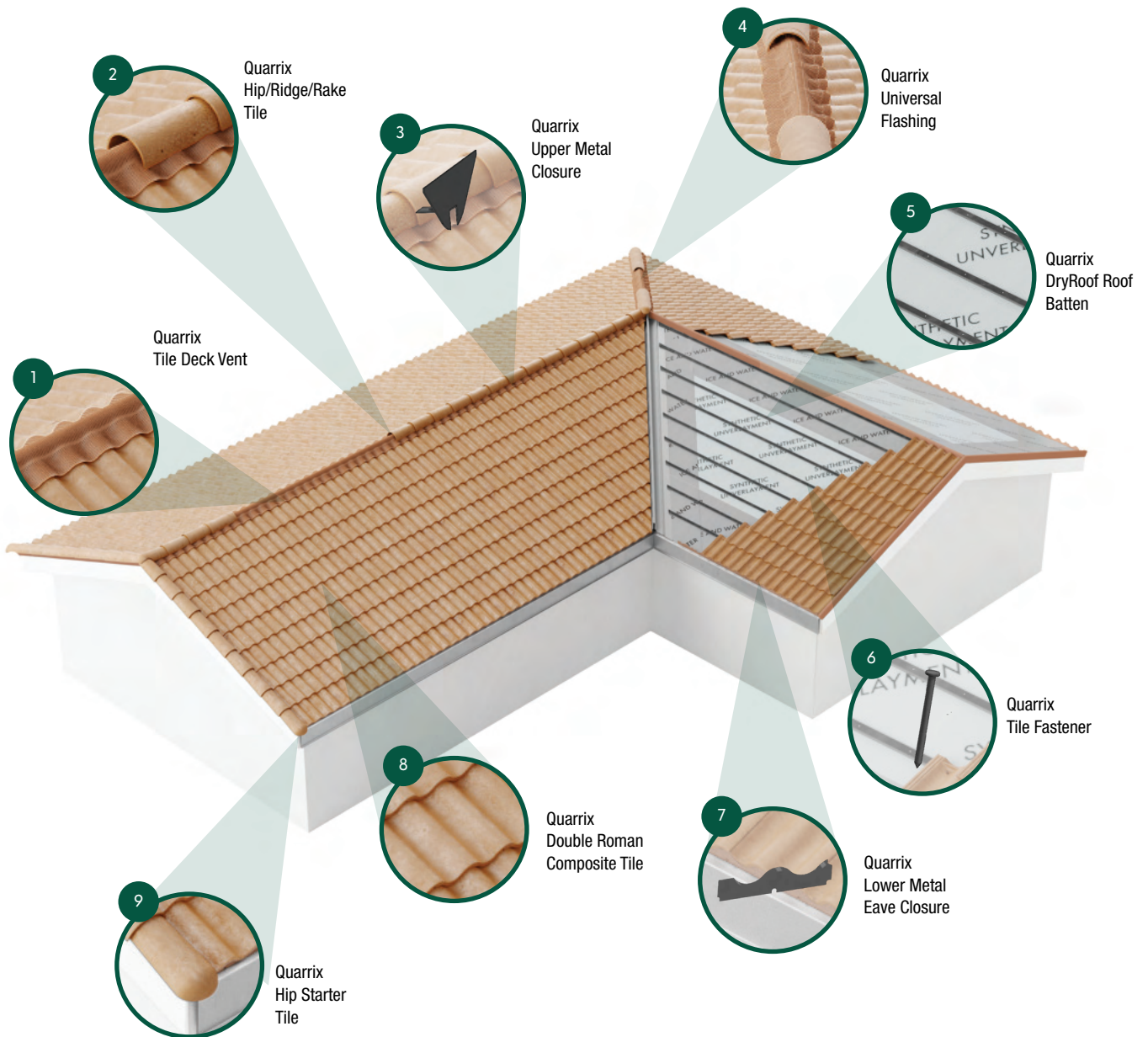

IMPERIAL FIELD TILE CHARACTERISTICS



Desert Red
Class C-3001DR
Class A-5001DR



Goldenrod
Class C-3001GR
Class A-5001GR



Saddle Brown
Class C-3001SB
Class A-5001SB



Canyon Earth
Class C-3001CE
Class A-5001CE



Sage
Class C-3001SG
Class A-5001SG



Black
Class C-3001BK
Class A-5001BK

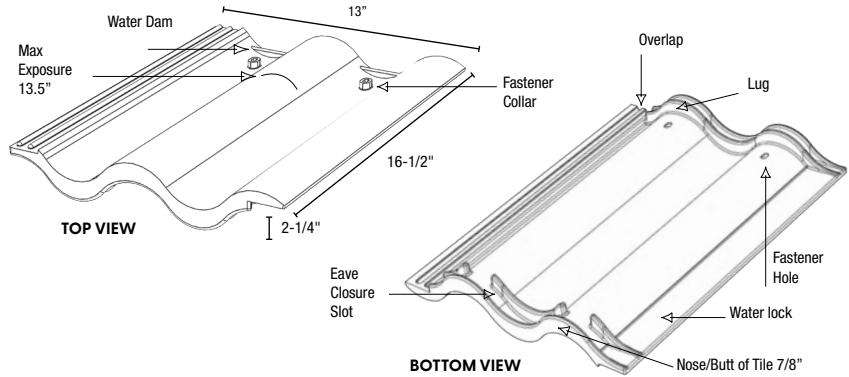

<p>OVERALL DIMENSIONS 13" x 16-1/2" x 2-1/4"</p> <p>MAXIMUM EXPOSURE 13-1/2" Height 11-19/32" Width</p>	<p>POUNDS PER SQUARE Class A - 297 lbs. Class C - 270 lbs.</p> <p>IMPACT RATING Class 4 (FM 4473)</p>	<p>BURNING BRAND Class A / Class C</p> <p>MATERIAL Polyethylene Polymer</p>	<p>SHIPPING INFORMATION Class A - 3.3 lbs. per piece Class C - 3 lbs. per piece 90 pieces per square 3 squares per pallet (1 square = 100 sq ft)</p>
---	---	---	---

NOTE: Metric measurements available on pg. 28 of Appendix.

IMPERIAL HIP/RIDGE/RAKE TILE CHARACTERISTICS



Desert Red
Class C-3077DR
Class A-5077DR



Goldenrod
Class C-3077GR
Class A-5077GR



Saddle Brown
Class C-3077SB
Class A-5077SB



Canyon Earth
Class C-3077CE
Class A-5077CE



Sage
Class C-3077SG
Class A-5077SG



Black
Class C-3077BK
Class A-5077BK

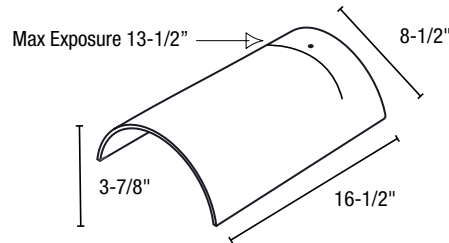

<p>OVERALL DIMENSIONS 8-1/2" x 16-1/2" x 3-7/8"</p>
<p>MAXIMUM EXPOSURE 13-1/2"</p>
<p>WEIGHT PER PIECE 2 lb</p>

NOTE: Metric measurements available on pg. 28 of Appendix.

IMPERIAL HIP STARTER TILE CHARACTERISTICS



Desert Red
Class C-3078DR
Class A-5078DR



Goldenrod
Class C-3078GR
Class A-5078GR



Saddle Brown
Class C-3078SB
Class A-5078SB



Canyon Earth
Class C-3078CE
Class A-5078CE



Sage
Class C-3078SG
Class A-5078SG



Black
Class C-3078BK
Class A-5078BK

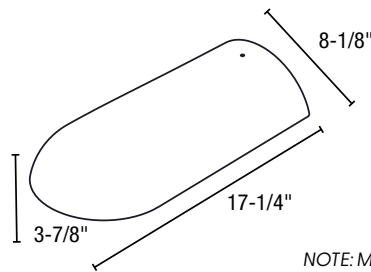

<p>OVERALL DIMENSIONS 8-1/8" x 17-1/4" x 3-7/8"</p>
<p>MAXIMUM EXPOSURE 13-1/2"</p>
<p>WEIGHT PER PIECE 1.90 lb</p>

NOTE: Metric measurements available on pg. 28 of Appendix.

IMPERIAL DRYROOF ROOF BATTEN CHARACTERISTICS

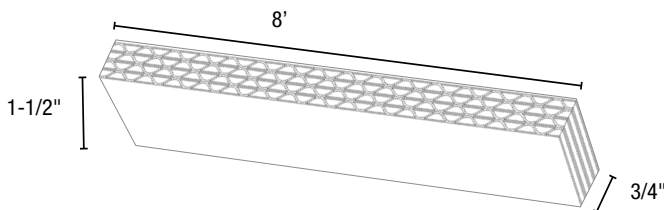

<p>OVERALL DIMENSIONS 8' x 1-1/2" x 3/4"</p>
<p>NFA 5.6 sq. in./lin ft.</p>
<p>MATERIAL HPDE Plastic</p>

NOTE: Metric measurements available on pg. 28 of Appendix.

MEASUREMENTS

IMPERIAL TILE DECK VENT CHARACTERISTICS

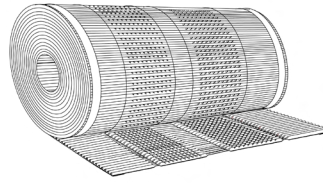

OVERALL DIMENSIONS

Black 15" x 25'
 Terra Cotta 15-3/4" x 16'
 Venetian Red 15-3/4" x 16'
 Brown 15-3/4" x 16'

MATERIAL

UV-Resistant Aluminum

NOTE: Metric measurements available on pg. 29 of Appendix.

IMPERIAL UNIVERSAL FLASHING CHARACTERISTICS

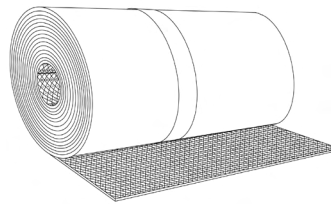
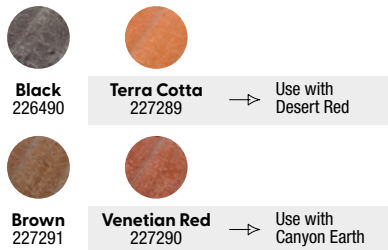

OVERALL DIMENSIONS

11-3/4" x 16'

MATERIAL

UV-Resistant Aluminum

NOTE: Metric measurements available on pg. 29 of Appendix.

IMPERIAL UPPER METAL CLOSURE CHARACTERISTICS

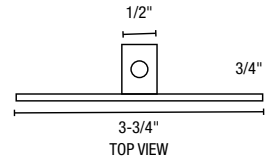
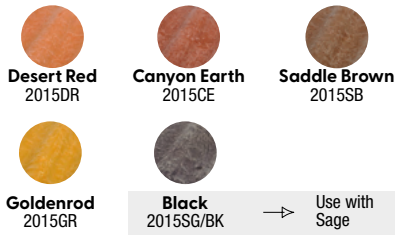

OVERALL DIMENSIONS

3-3/4" x 3/4"

MATERIAL

Kynar-coated, G90 galvanized steel.

NOTE: Metric measurements available on pg. 29 of Appendix.

IMPERIAL LOWER METAL EAVE CLOSURE CHARACTERISTICS

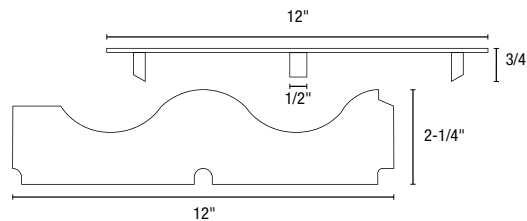
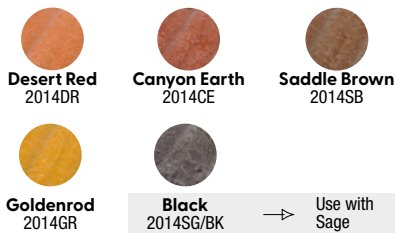

OVERALL DIMENSIONS

12" x 2-1/4"

MATERIAL

Kynar-coated, G90 galvanized steel.

NOTE: Metric measurements available on pg. 29 of Appendix.

IMPERIAL FASTENER CHARACTERISTICS

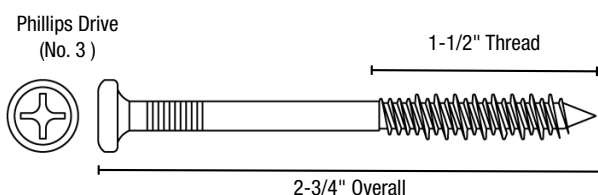

OVERALL DIMENSIONS

#10 x 2-3/4"

NOTE: Metric measurements available on pg. 29 of Appendix.

SPECIALTY TOOLS TO MAKE THE JOB EASIER



4" Diamond-tipped turbo blade on angle grinder



Saw equipped with a carbide or segmented diamond-tipped blade (8"-10")



Safety personal protective equipment as required by OSHA and other local and state agencies

MATERIALS CHECKLIST

Quarrix System Advantage Products:

- Double Roman Tile
- Tile Fasteners
- Tile Battens
- Tile Deck Vent
- Universal Flashing
- Lower Metal Eave Closures
- Upper Metal Closures
- Hip Starter Tile
- Hip/Ridge/Rake Tile

Other Required Products:

- Plywood Sheathing
- Wood Nailer (2x4/2x2)
- Synthetic Underlayment
- Ice and Water Shield
- Metal Flashing
- Metal Drip Edge
- Sealant/Adhesive
(Geocel 3500 recommended)

COLD WEATHER CONSIDERATIONS

Our tile has been tested for and installed in every climate zone in North America. The tile's ability to withstand the hottest summers and the harshest winters, without any freeze/thaw issues, make it a great product in any climate. It is recommended that the actual temperatures at the time of installation be in the 40 to 120 degree Fahrenheit range to ensure proper adhesion of the underlayments, Quarrix Universal Flashing, and other required sealants and adhesives.

In some areas snow guards may be desired to control unexpected snow and ice avalanches from the finished roof. We do not manufacture snow guards, but selections of various metals and designs especially engineered for Quarrix Double Roman Composite Roof Tile can be purchased through Alpine Snow Guards in Morrisville Vermont. Visit Alpinesnowguards.com for more information.

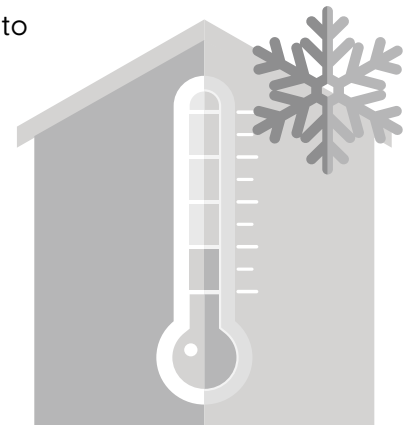

INSTALLATION TIPS AND ALWAYS/NEVER GUIDE

ALWAYS	NEVER
<p>✓ Always lay out the roof so that all horizontal rows have equal exposure.</p>	<p>⊘ Never exceed the maximum exposure of 13-1/2".</p>
<p>✓ Always install the lower metal eave closure resting comfortably on the drip edge.</p>	<p>⊘ Never let the lower metal eave closure hang over the drip edge.</p>
<p>✓ Always "hang" or interlock several tiles and align before fastening.</p>	<p>⊘ Never secure one tile at a time, as horizontal alignment will be very difficult.</p>
<p>✓ Always secure each tile at two points; screws, nails, tie wires, adhesive, etc.</p>	<p>⊘ Never rely on one point, one method; even with small cut pieces.</p>
<p>✓ Always use Quarrix fasteners, or comparable stainless steel fasteners.</p>	<p>⊘ Never use fasteners that can corrode and fail.</p>
<p>✓ Always use adhesives that are specially formulated for HDPE plastics.</p>	<p>⊘ Never use general adhesives that will not bond to HDPE.</p>
<p>✓ Always cover deck with quality ice and water shield and synthetic underlayments.</p>	<p>⊘ Never install tile over existing shingles.</p>
<p>✓ Always follow installation guide when forming tile flashings.</p>	<p>⊘ Never use typical flat shingle type flashings.</p>
<p>✓ Always shuffle/mix tile from different bundles and different pallets.</p>	<p>⊘ Never create potential color variations with adjacent bundles or pallets.</p>
<p>✓ Always follow the Quarrix Composite Tile Installation Guide.</p>	<p>⊘ Never be afraid to contact Quarrix directly at 800.438.2920 for any assistance.</p>

BEFORE GETTING STARTED

PREPARING THE ROOF DECK FOR INSTALLATION

We recommend as a best practice the entire Quarrix System Advantage tile component system be installed to provide the best foundational system and long-term protection. Quarrix composite tile can be installed directly to the deck and will require sourcing different full threaded nails. However, the use of Quarrix DryRoof Roof Battens in the tile component system will provide significant advantages such as reducing installation time and ensuring proper drainage and airflow under the tile. We explain how-to-install Quarrix tile components as well as alternative roofing components in this guide.

All tile and slate roofs are water shedding roofs, and not waterproof roofs like shingles or various membranes. Therefore proper underlayment and specialty flashings are necessary to provide a watertight deck before tile installation. Any roof with a slope less than 4:12, should have a waterproof membrane on the deck, capable of self-sealing around any tile fasteners. It is essential that all previous roofing materials be torn off before starting the Quarrix composite tile installation process.

Wherever sealants or adhesives are called for, be sure to use only those products that are specifically formulated for HDPE (high density polyethylene) as other plastic sealants may not adhere properly.

PRE-PLANNING YOUR FLASHING SOLUTIONS

Flashing is another critical component to the Quarrix tile component system. Quarrix Universal Flashing is a flexible, expandable, fully self-adhered closure solution that can be used wherever weather blocking or mortar might be required in a conventional tile installation. Quarrix Tile Flashing can be used as a primary flashing, a counter flashing, or in conjunction with specially formed metal flashings. Quarrix does not provide bent metal flashings but details are provided in the Appendix starting on page 24. Flashing can be sourced locally to fit your custom job specifications. Flashing should comply with all applicable local codes.

FASTENERS

Quarrix fasteners offer the best solution for attaching battens, tile, or tile trim pieces to the deck.

LEVEL OF EXPERTISE NEEDED

We highly recommend that tile roofs be installed by a professional roofing contractor. While it is possible for a well-skilled homeowner to install a small tile roof project by following this guide, larger or more complex roof structures should be installed by a licensed contractor that has tile, slate or high-end roofing product installation experience.

MAINTAINING WARRANTY

The Quarrix composite roof tile warranty offers protection against manufacturing defects found in the tile so as to not rot, split, splinter or suffer structural damage for up to 50 years. Ultimately, roof performance is equally dependent on all materials used and quality of workmanship exhibited during the installation process. Quarrix does not require or provide inspections or certifications of warranty compliance during or upon completion of the installation process. Attention to detail and adherence to the Quarrix Installation Guide, TRI/WSRCA Tile Installation Manual, and commonly accepted roofing practices will ensure a quality installation. For more information or to register a tile warranty, visit Quarrix.com/warranty.

BEFORE GETTING STARTED

DECKING

Quarrix composite tile shall be installed over code-complying, minimum 15/32" (11.906 mm) plywood sheathing for the roof decking.

NOTE: It is mandatory to remove all previous roofing materials prior to Quarrix composite tile installation.

UNDERLAYMENT

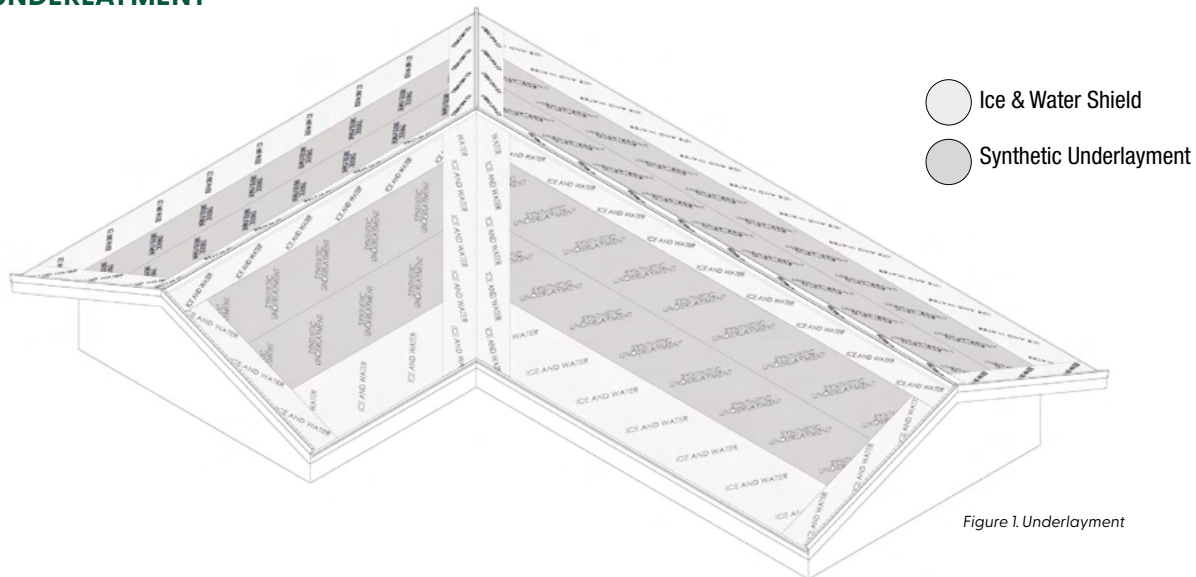

For roof slopes 4:12 and above, the use of quality ice and water shield products and synthetic underlayment will provide optimal performance when used in accordance with their respective manufacturer's application instructions. Use self-sealing membrane that meets or exceeds requirements of ICC-ES AC 48 along roof perimeters and protrusions. Underlayment should be installed parallel to the roof eave with a 6" (15.24 cm) lap on the ends. A 3" (7.62 cm) side lap and a minimum 1/4" (6.35 mm) lap over eaves.

Class C: Roof underlayments necessary for obtaining the classification in the tests shall be manufactured under a listing program of an inspection agency accredited by the International Accreditation Service, or otherwise acceptable to ICC-ES.

Self-sealing membrane is required up the roof deck at least 2' (60.96 cm) inside the exterior wall, 6' (1.83 m) in the valleys and 3' (91.44 cm) around protrusions, gables, walls and under valley flashings. For better protection, smaller roofs, and lower slopes, self sealing membrane may be used on the entire roof deck. High temperature underlayments are not required, but may enhance performance. Heavy granulated underlayments are not recommended.

"Always cover deck with quality ice & water & synthetic underlayments."

Quarrix Class A tile has achieved an ASTM E108 Class A fire rating when installed over two layers of GAF VersaShield and is recommended for when a Class A fire rating is required. Alternative underlayment use must be manufactured under a listing program of an agency accredited and acceptable to ICC-ES as a Class A underlayment and installed according to manufacturer requirements to achieve an overall Class A roof system.

NOTE: Underlayment and flashings are weather-shedding devices for the roof system; the building should be water-tight before tile is installed.

BATTENS

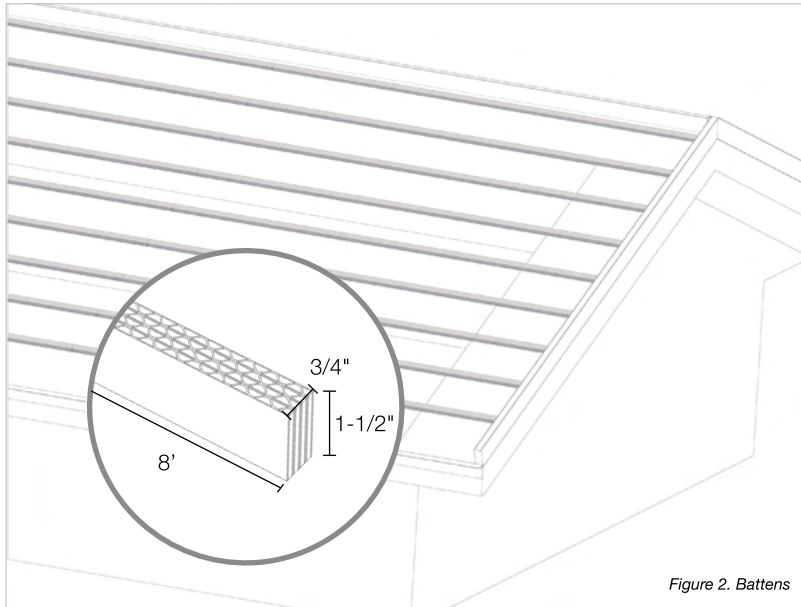

Figure 2. Battens

Best practice construction methods recommend installation of tile with battens, but direct to deck installation is allowable. Different fasteners will need to be sourced with a full thread for this installation method.

Quarrix DryRoof Roof Battens are constructed of specially-formulated UV-resistant corrugated plastic, designed to allow moisture drainage and air movement under the tile. Taller than traditional wood battens, they keep the tile lug from making contact with the underlayment, reducing the chance for leaks. The HDPE plastic design creates a gasket effect which

eliminates leaking around fasteners. They have a lifetime limited warranty, and while not required, are highly recommended for all Quarrix Double Roman Composite Roof Tile installations.

It is possible to apply Quarrix composite tile directly to the underlayment on the deck. However, the steeper the pitch and the longer the horizontal runs, the more difficult it will be to keep tile rows in alignment. Given the interlocking design of the tile, it is easier to maintain alignment by “hanging” and positioning several tiles horizontally, on the battens, before finally securing them to the deck. This ability to pre-position tiles before fastening will be invaluable when laying out roof facets to predetermine cuts and spacing’s for rake and other terminations. Quarrix fasteners are specifically designed for installation with battens. Different fasteners will need to be sourced with a full thread for this installation method.

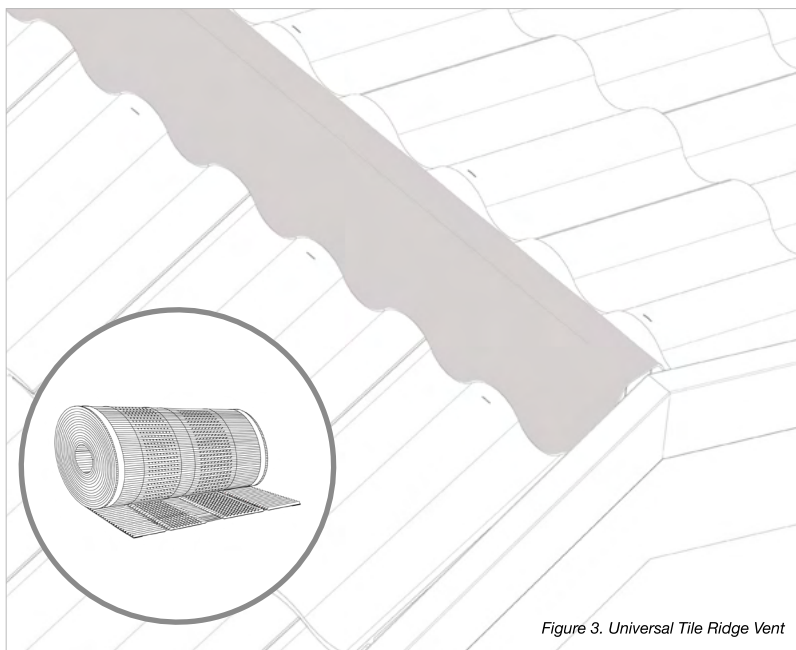

Figure 3. Universal Tile Ridge Vent

NOTE: If using wood battens, they shall be nominal 1" x 2" x 8' (2.54 cm x 5.08 cm x 2.44 m) pressure-treated wood battens with drainage notches or ports 16" (40.64 cm) on center.

TILE DECK VENT

Quarrix all-in-one Tile Deck Vent at the ridge assists in deck ventilation and air flow under tile and helps achieve a cool roof system. Available in the following colors: Black, Terra Cotta, Venetian Red & Brown.

TILE COLOR MATCHING

- Terra Cotta tile deck vent is used with Desert Red composite tile.
- Venetian Red tile deck vent is used with Canyon Earth composite tile.

Please give us a call at 800.438.2920 if you have any questions about choosing the right color.

FLASHING AND WEATHER BLOCKING

All roof penetrations require two flashings: a primary flashing on the deck and a counter flashing on the tile. Weather blocking and flashing should be used in all areas where the roof butts a vertical wall, dormer, chimney, skylight or other structural protrusion. Flashing should extend 4" (10.16 cm) up vertical walls. Flashings shall be one of the following: 16 or 20-ounce copper, lead-coated copper, terne-coated stainless steel, 24-gauge prefinished colored steel, 26-24 gauge galvanized sheet steel, aluminum or equivalent. Flashing shall comply with applicable codes.

“Always follow installation guide when forming tile flashings.”

Technically, it is possible to use mortar or grout with composite tile but in reality, these products do not adhere as well to composite products as they do to clay or concrete tile. There are some synthetic roof mortars like Flexim (www.flexim.eu/en/) available which are much more suitable for packing any openings in composite tile. Overall the recommended choice to meet both weather blocking and flashing requirements is to use Quarrix Universal Flashing.

UNIVERSAL FLASHING

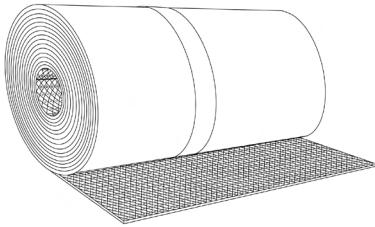

Quarrix Universal Flashing is a fully-adhered, expandable aluminum flashing with a width of 11-3/4" that effectively covers all roof to wall applications. It can be used as a primary flashing, a counter flashing or in combination with bent metal flashings. It will easily conform to a Double Roman profile for a weather-tight seal when used as a weather block, or wherever mortar would be required; headwall, chimney, hip, ridge, gable end, skylight or pipe stack. It is available in the following colors: Terra Cotta, Venetian Red, Black and Brown.

TILE COLOR MATCHING

- Terra Cotta Universal Flashing is used with Desert Red composite tile.
- Venetian Red Universal Flashing is used with Canyon Earth composite tile.

Please give us a call at 800.438.2920 if you have any questions about choosing the right color.

VALLEYS

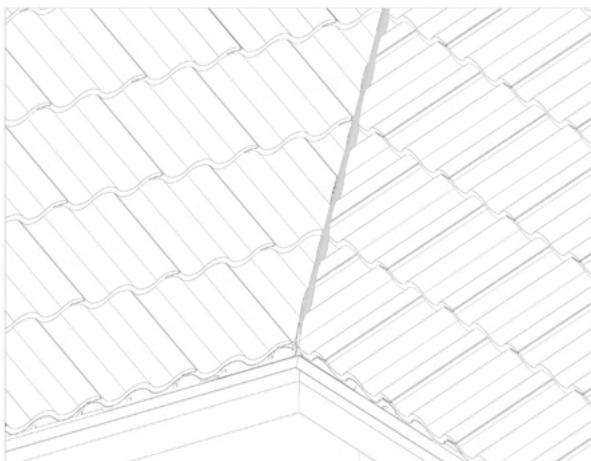

Valley metal should be a minimum 28-gauge steel painted to match tile. An ice and water shield is recommended as underlayment in all valleys. Lap flashings should be a minimum of 4" (10.16 cm) for slopes 4:12 and above, and 6" (15.24 cm) for slopes below 4:12. Extend the bottom edge of the valley metal past the eave metal about 1" (2.54 cm) and bend slightly down to form a drip edge. Cut tile pieces need to be secured in two locations. Fasteners, wires, adhesives and clips are all good options to use. Always follow installation guide when forming tile flashings.

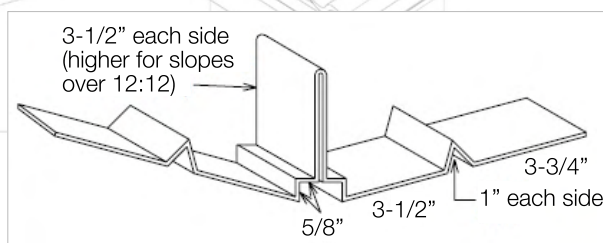

**Refer to Appendix C on pg. 26 for details on open and closed valley flashing. Generally speaking a closed valley will provide the most aesthetically pleasing valley configuration.*

Figure 4. Closed Valley Flashing

DRIP EDGE & RAKE EDGE

Drip edge metals should be a minimum 28-gauge steel and painted to match to be compatible with Quarrix painted steel lower metal eave closures. Ice and water underlayment should be used under the drip edge as well as lapping onto the drip edge. Metal flashing or Quarrix Universal Flashing is required on gable ends as well.

NOTE: Refer to Appendix A & B on pages 24 & 25 for details on metal flashings.

UPPER METAL CLOSURES

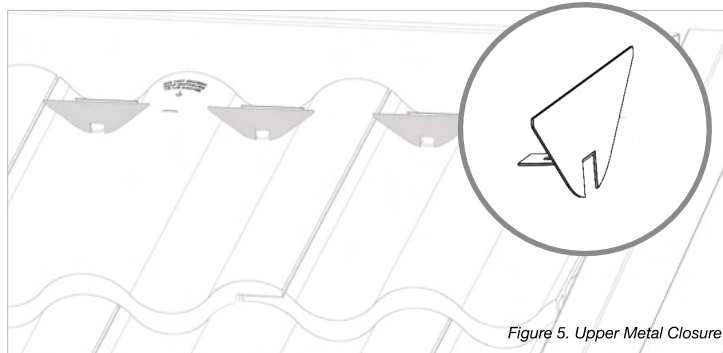

Quarrix Upper Metal Closures are designed for additional weather blocking in the top rows of tile installations. Typically, they are used in conjunction with pan flashing on roof to wall applications or in some ridge tile applications. If Quarrix Universal Flashing is used, upper metal closures are not required. Offered in compatible colors or black, these pieces attach to the tile as it is being fastened with the Quarrix Fastener. Two closures are needed for each tile. All

Quarrix metal closures are G-90 galvanized steel, Kynar coated 24 gauge.

LOWER METAL EAVE CLOSURES

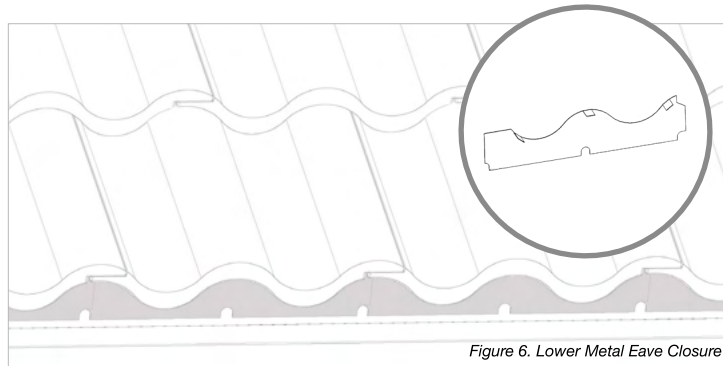

Quarrix Lower Metal Eave Closures, also commonly referred to as bird stop or bat stop, are individual painted steel pieces that snap into the Quarrix tiles located on any eave edge (the first row in any application). All Quarrix metal closures are G-90 galvanized steel, Kynar coated 24 gauge. Offered in compatible colors or black, these pressure fitted pieces fill what otherwise would be a visible void along the lower roof edge. The closure

sets on top of the metal drip edge and provides a weep hole for any moisture under the tile to escape. Apply one closure to each eave tile prior to fastening the tile.

Note: Be careful to avoid putting full weight on tiles with closures to avoid bending of the metal. In areas where you will be stepping on tiles with closures, additional structural support such as wood or doubled-up sections of Quarrix battens will help minimize crushing.

SEALANTS/ADHESIVES

Use adhesive to secure cut pieces of tile along hips, valleys, gables, sidewalls and protrusions, and to install hip and ridge caps. Concealed sealants along ridge/hip trim and flashings shall be urethane, silicone or other higher end multi-polymer products. Colored mortar/grout or Quarrix Universal Flashing may also be used along hips and open valleys and can be used in lieu of ridge closures along ridges. See sealant manufacturer's installation instructions for details.

“Always use adhesives that are specially formulated for HDPE plastics.”

NOTE: All adhesive used need to be compatible with HDPE. Geocel 3500 is a good choice for a sealant/adhesive.

TILE FASTENERS

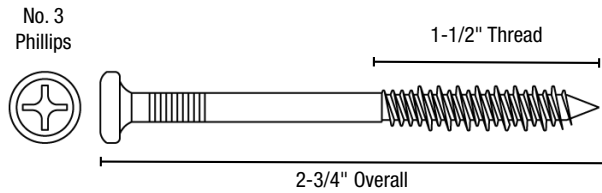

Quarrix Tile Fasteners are specially engineered and recommended for securing all Quarrix composite tile. Fasteners must penetrate the roof deck at least 3/4" (19.05 mm). Tile Fasteners are available in 1200-count pails and 100-count packs. Colors available: Black.

Tile Fasteners – Use screws for maximum wind resistance: Two 2-3/4" (6.98 cm), non-corrosive No. 10 coarse thread, .344"- diameter (8.74 mm) pan-head screws. This will allow for 1/4" (6.35 mm) penetration through sheathing. If using nails: two non-corrosive, 2-3/4" (5.08 cm), 10/11-gauge, ring-shank (18 rings/inch), 3/8"-diameter (9.53 mm) head nails. This will allow for 1/4" (6.35 mm) penetration through sheathing, when using Quarrix tile battens. Quarrix fasteners are designed to work optimally with battens. Direct to deck fasteners should have a full thread with similar diameter and head specifications.

“Always use Quarrix fasteners, or comparable stainless steel fasteners.”

Batten Fasteners – Wood or Quarrix battens should be fastened every 10" using nails or screws that are non-corrosive and of sufficient length to fully penetrate the roof sheathing.

Underlayment Fasteners – Fasteners for underlayment shall be 11-gauge roofing nails with 3/8" (9.53 mm) heads with sufficient length to penetrate into the sheathing 3/4" (19.05 mm) or through the sheathing, whichever is less.

Flashing Fasteners – Flashing shall be fastened with 11-gauge, ring-shank, corrosion-resistant nails compatible with the flashing material with sufficient length to penetrate the sheathing 3/4" (19.05 mm) or through the sheathing, whichever is less.

“Always secure each tile at two points – screws, nails, tie wires, adhesives, etc.”

Hip and Ridge Trim – Fasteners for hip and ridge trim shall be No. 10, coarse-thread, 0.344"-diameter (8.74 mm), corrosion-resistant pan-head screws (same as tile fasteners). Use 2-3/4" (6.98 cm) long for ridges and 2-3/4" (6.98 cm) long for hips. A 3" (7.62 cm) non-corrosive, ring-shank nail in combination with an approved adhesive under the nose of each trim piece can also be used.

NOTE: Quarrix tile fasteners are recommended for tile and accessories to provide optimal performance..

INSTALLATION AT-A-GLANCE

Generally speaking, the overall sequence for installing Quarrix Double Roman Composite Roof Tile is as follows:

STEP 1: Prepare the deck with proper underlayment.

STEP 2: Install necessary wood nailers; ridge, hip and rake.

STEP 3: Apply necessary flashings; eave metals, valleys, rake, penetrations, etc.

STEP 4: Determine exposures and snap reference lines and apply battens.

STEP 5: Load the roof with field tile.

STEP 6: Install first row of tile with lower metal eave closures working from right to left.

STEP 7: Install field tile mindful of exposures (13-1/2" max), and horizontal and vertical alignments.

STEP 8: Apply upper metal closures or tile ridge vent, and pan or counter flashings as needed.

STEP 9: Apply Quarrix Universal Flashing as weather blocking to hips and ridges.

STEP 10: Apply Quarrix Hip Starters and Quarrix Hip/Ridge/Rake trim tile to hips, rakes and ridges.

STEP 1

Preparing the Deck for Installation

Start by making sure the deck, drip edge, valleys and underlayment have been correctly installed according to code (see page 10) and all previous roofing materials have been removed.

STEP 2

Wood Nailers; Ridge, Hip & Rake

When using Quarrix Hip and Ridge trim as a rake cap, either a raised rake fascia board or a 2x2 rake nailer will give the best angle and mounting surface for the Hip and Ridge trim tile. Please see Step #9 Rake Installation, pages 21 and 22 for further detail. All hips, ridges, and rakes will require an additional nail base for the Quarrix trim pieces (the hip/ridge/rake all use the same trim piece). Typically, a 2x4 on edge will provide the approximate needed height, but the exact nailer height will vary with roof slope. The hip/ridge/rake piece should rest on the composite field tile and the nailer with minimal spacing and a smooth appearance. Often times a Quarrix Batten can be added to the top of the nailer to achieve the desired height. All nailers should be wrapped in ice and water underlayment prior to installation.

“Always follow the Quarrix Composite Tile Installation Guide”

STEP 3

Flashings & Penetrations

All primary flashings can be installed at this point, such as: eave edge metals, preformed valley flashing, preformed gable flashings, chimney flashings, sidewall flashings, etc. including Quarrix Universal Flashing where utilized as a primary flashing. All penetrations should be waterproof and sealed at the deck (they will receive counter flashings after the tile is installed).

STEP 4

Exposures & Battens

Prior to starting any tile job, the roof will have to be laid out with the goal of having equally exposed vertical rows of tile, none of which ever exceed 13 1/2" (13" in high wind areas). Because of intersecting roof planes and with different rake dimensions, some sections may require "short rows" either at the top or bottom of some roof sections.

"NEVER exceed the maximum exposure of 13-1/2"

For batten installation, strike the lines centered on each hip if applicable. Then strike the horizontal line at 15" (38.1 cm) (16" or 40.64 cm for direct to deck) for the top edge of the eave batten above the eave edge to ensure proper fit of the bottom row of the tiles. At this point, verify that the Quarrix Tile with the lower metal closure installed, will rest comfortably on the drip edge. Some drip edge configurations will require moving this line up slightly to prevent the closure from overhanging the drip edge. Next, strike the horizontal line for the top edge of the top batten 1" (2.54 cm) (1/4" or 6.35 mm for direct to deck) down from the ridge center line. Then divide the distance between these two lines into equal increments, not to exceed 13-1/2 (34.29 cm) and strike lines for the top edges of each row of battens.

If different eave heights on the same roof plane do not allow for equal spacing, lay out the largest area first as described on page 19. On the smaller area, snap the eave line at the proper eave spacing and align the remaining lines with those already established on the larger roof plane. The results may reduce the spacing between the first and second lines of the smaller roof area, reducing the exposure of the bottom row of the tiles. If different ridge heights do not allow for equal spacing, add a short row along the shortest ridge. If a short row is required, cut the head off the tile piece and install a batten along the ridge so the short row maintains the same slope as the rest of the tiles.

"Always lay out the roof so that all horizontal rows have equal exposure"

Vertical alignment on Quarrix interlocking tile is for the most part controlled by the natural seat of the interlocking channels of the adjacent tiles. However, it is important to establish a true vertical alignment prior to application to assure a symmetrical installation. Various methods for establishing true vertical alignment can be found in TRI/WSCRA manuals, but essentially vertical lines 58" apart, (as described in the roof loading paragraph on page 19) will assist in saving time and effort and insure an enhanced overall appearance.

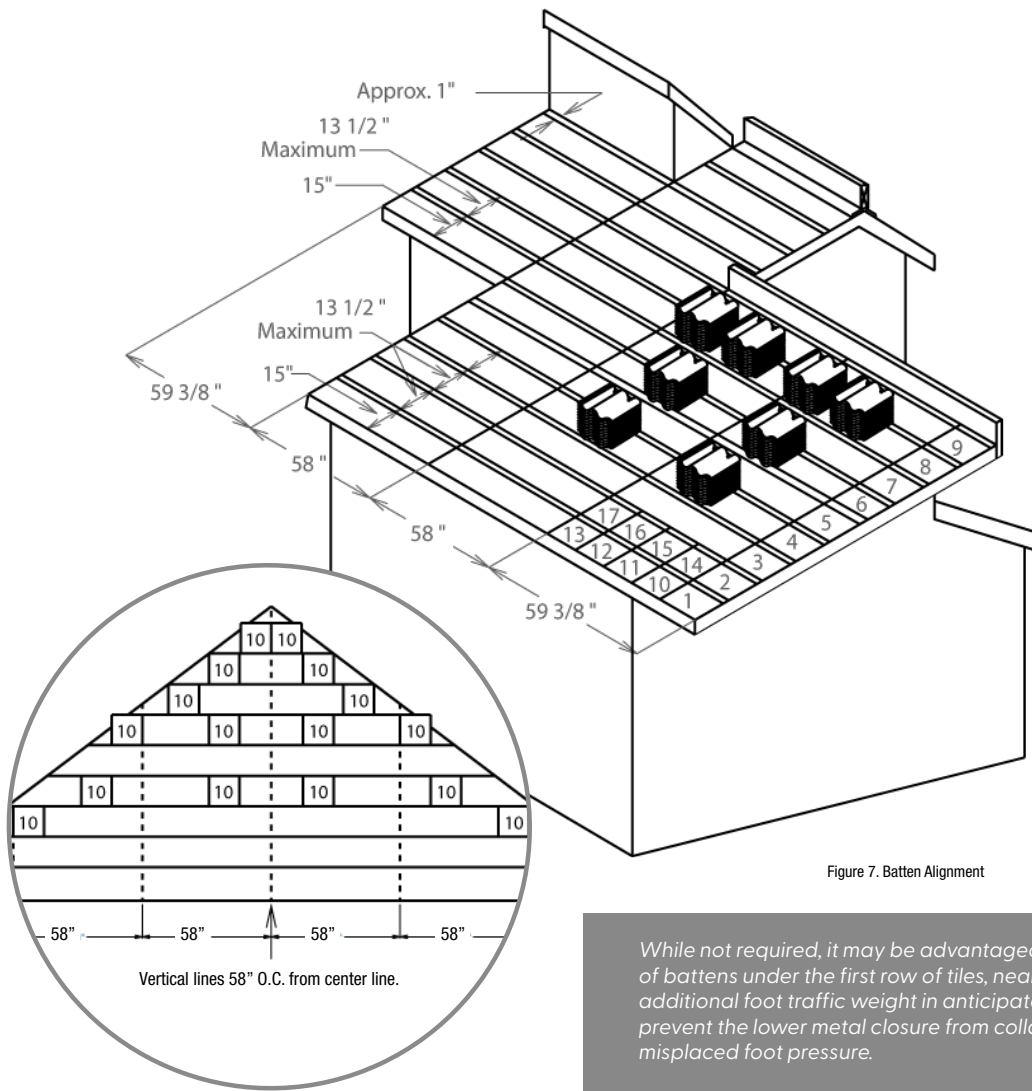

Figure 7. Batten Alignment

Tiles can be very slippery when wet & caution should be taken when walking on them. Toe-boards and OSHA approved harnesses & safety equipment should be used at all times.

NOTE: Stack 2-3 extra tile on the top stacks if you have an uneven number of rows.

While not required, it may be advantageous to add a double row of battens under the first row of tiles, near the roof edge, to support additional foot traffic weight in anticipated roof access areas. This will prevent the lower metal closure from collapsing unexpectedly from misplaced foot pressure.

Batten Installation (Recommended)

Align the batten along the pre-chalked line. Nail or screw the batten 2" (5.08 cm) from each end. Nail or screw the battens every 10" (25.4 cm). Quarrix DryRoof Roof Battens are not structural support for tile. Tile fasteners need to penetrate the roof deck through the battens by a minimum of 3/4" (19.05 mm). A utility knife can be used for cutting tile battens.

When applying Quarrix DryRoof Roof Battens, it is recommended to install one roof plane at a time and not leave battens exposed an extended time to heat and sun as movement may occur prior to being covered by field tile.

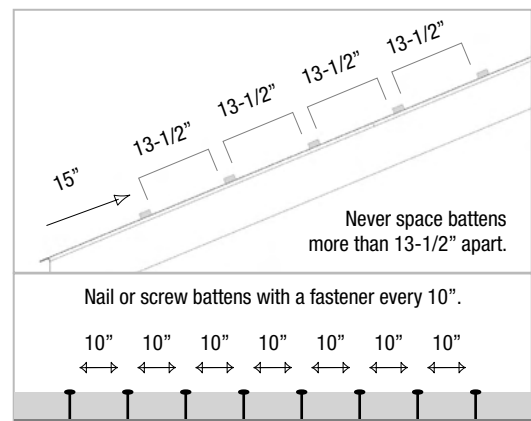

Figure 8. Batten Installation

STEP 5

Roof Loading

Generally, the proper loading of a tile roof is significant because of the needed weight distribution of heavier clay or concrete tiles. Quarrix Composite Tiles are significantly lighter, so this is less of a concern. However, the proper placing and mixing of tiles from different pallets and different bundles will expedite the installation process and insure proper blending.

Before loading the roof, check to ensure that all battens, underlayment and flashings are clear of all debris. Also make sure that any holes or damage is repaired. For gable roofs strike vertical lines 58" (1.47 m) O.C. after establishing the starting line approximately 59-3/8" (1.52 m) from the inside edge of the gable fascia. On hip roofs strike the vertical line at the midpoint of the eave to the apex of the hips. Strike vertical lines 58" (1.47 m) O.C. on either side of that center line. Add extra stacks along the hip and valley to allow for one tile per row to be cut on each side. Adjust the starting line to allow for proper rake fit at the gable. Randomly stack tile five high between the chalk lines throughout the roof. Then stack five more tiles randomly on top of the existing stacks to get a good color blend across the entire roof. Stack four to five ridge trim on the ridge, centered on every vertical chalk line. Stack two to three extra tiles on the top stacks if you have an uneven number of rows. The bottom two battens should be kept free of tile stacks. If blending multiple tile colors, order appropriate amount of each color and blend colors randomly on the job site for blended desired final appearance.

STEP 6

Lower Metal Eave Closures

Lower metal eave closures are used to close the opening under the barrels and provide the proper edge for tile at the eaves, flat roof eaves and flat saddles. Place the closure in the closure slot along the bottom underside of each eave tile with the colored side facing the eave. Press the closure down firmly to the bottom of the slot to lock it in place. Closures are designed to be pressure fitted, but if for any reason it does not feel secure, an HDPE sealant (like Geocel 3500), can be used to secure the metal to the tile. Closures are designed for 3/8" (9.53 mm) side overlap and should rest 1/4" (6.35 mm) up from the bottom edge of the eave metal. Lower metal closures sit on the drip edge, they do not overhang it. This will assure a correct roof slope for the first row of tile.

“Always install the lower metal closure resting comfortably on the drip edge”

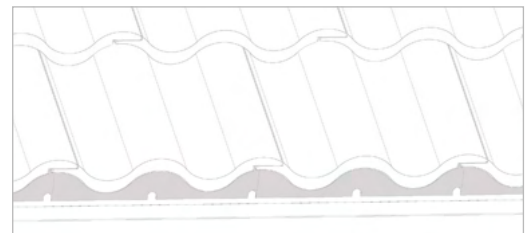

Figure 6. Lower Metal Eave Closure

STEP 7

Field Tile Installation

Tile should be installed from right to left as viewed facing the ridge. The right edge of the tile will lock into the left side of the tile laid before. When the tile is laid in a half-joint pattern, every other row lands on the marked vertical line. This sets the course-to-course offset. Install the tile using both fastener holes on every tile. Install the tile using the same exposure determined in the roof layout (never to exceed 13-1/2"). The tile will be more aesthetically pleasing if the break between the tile is offset between courses. In other words, don't align joints vertically in field tile installation. The tile must be cut to fit at hips and valleys. Tile cuts at rake edges need to be predetermined for fit of the rake cap or the boxed end. Generally speaking, one would work from the rake edge to the cut edge (valley or hip), even if the direction is left to right. The use of Quarrix battens allows the full layout of the horizontal row prior to fastening, for ideal positioning. Installers MUST blend the tile pieces from various pallets and bundles in order to achieve a distinct surface look. Quarrix composite tile is designed to provide a random and varying aesthetic appearance.

“Always hang several tile and align before fastening.”

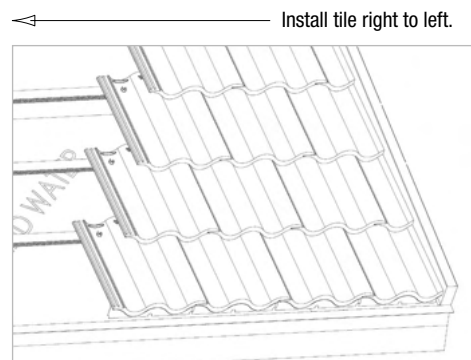

Figure 9. Field Tile Installation

“Always shuffle/mix tile from different bundles and different pallets.”

Note: Tile is slippery, especially when wet. Use caution when installing the field pieces. Toe boards, OSHA-approved harnesses and safety equipment should be used at all times. If tiles are damaged by securing safety anchors, they can be replaced following the tile replacement section in this manual. Often times with battens, it is possible to work from above the tile when installing.

STEP 8

Upper Metal Closures & Pan Flashings

Upper metal closures or ridge closures are fastened with the tile fastener. They are used in conjunction with pan flashings, typically on headwall applications, or ridge applications that do not use the Quarrix Universal Flashing or Quarrix Tile Deck Vent. Position the top row of the tile and bend the closure so the ridge trim and flashing extend past the face of the ridge closure.

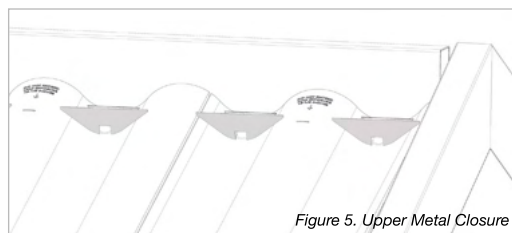

STEP 9

Weather Blocking

After the field tile has been installed and all tiles are loosely butted to the hip or ridge nailer, Quarrix Universal Flashing can be used as the weather block (in lieu of mortar).

Quarrix Universal Flashing elongates in both directions and is fully adhered. Working from eave to ridge, center the flashing on the hip nailer and begin to form the product to the tile roof surface. You can predetermine how much flashing you want exposed or concealed by the hip/ridge/rake trim piece, and snap vertical lines accordingly for a smooth appearance. Remove the protective strip and press all adhesive firmly to the tiles. When joining rolls of flashing, overlap the already applied rolls by 3" (7.62 cm). Excess material can be cut with a utility knife or sheet metal shears and used in other areas.

STEP 10

Hip Installation

Once the flashing is applied, start with a hip starter on the eave edge and continue with hip/ridge/rake trim. Hip pieces should be installed with 13-1/2" exposure (34.29 cm). They should be secured with two Quarrix fasteners in the overlap area (concealed), or two non-corrosive 3" ring shank nails. Adhesive should be applied on the underside and top edge of the hip trim to aid in wind resistance.

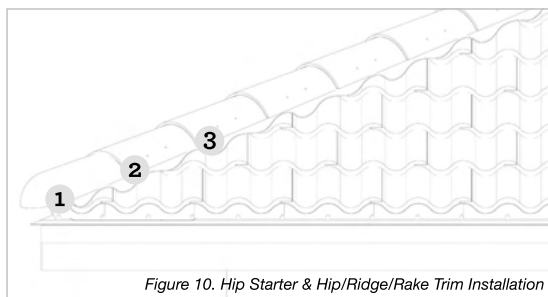

Ridge Installation

When all the field tile is installed up to the ridge nailer, Quarrix Universal Flashing, or Quarrix Tile Deck Vent can be applied to the ridge. Center the flashing or ridge vent on the ridge and loosely form the material to the tile roof surface. You can predetermine how much flashing or vent you want exposed or concealed and snap horizontal lines accordingly. Overlap any rolls by 3" (7.62 cm). Remove the protective strip and firmly press the adhesive into the tiles.

Once the flashing or ridge vent is applied, start with the hip starter and then apply the hip and ridge towards the wall or intersecting roof plane.

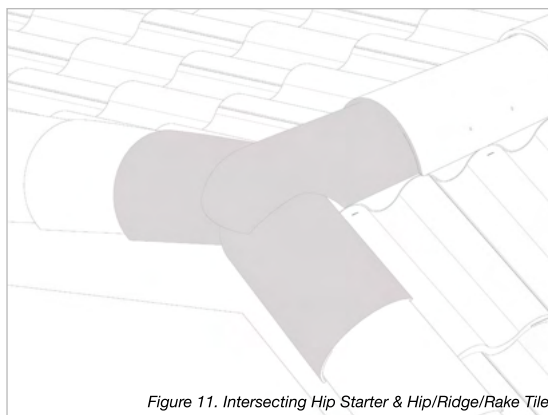

For a full ridge, apply hip starters on each end and work back to the center. The adjoining center pieces will have to be cut and capped (form a saddle) for a smooth appearance. Ridge pieces should be installed with 13-1/2" exposure (34.29 cm). They should be secured with two fasteners in the overlap area (concealed), or two non-corrosive 3" ring shank nails. Adhesive should be applied on the underside and top edge of the ridge trim to aid in wind resistance. Quarrix does not make trim pieces beyond the basic hip starter. For applications requiring intersections of multiple hips, or ridges and hips, the hip starter can be coped (cut) to rest level on underlying hip/ridge/rake trim tile and Quarrix Universal Flashing can be used to cover joints. Metal flashings can also be fabricated and painted to match for multiple intersections.

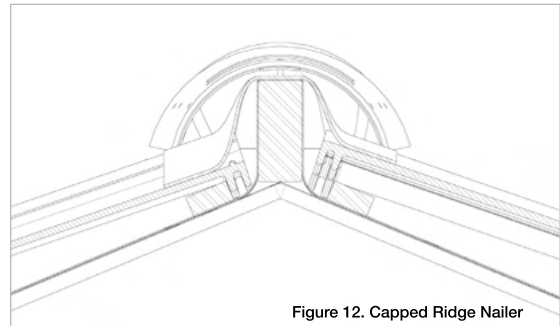

Figure 12. Capped Ridge Nailer

Rake Installation

Hip/ridge/rake tile can be used on rake edges to complete a typical tile aesthetic. It is also possible to box in the rake and simply butt the tile to the rake edge for a different appearance. In either case, the rake trim has to be raised (about 3"), or a wood nailer added to accommodate the thickness of the tile (and battens). The inside corner created on the deck must be flashed either with bent metal as described in the flashings appendix or Quarrix Universal Flashing. This must be part of the initial deck preparation as field tile adjoining the rake are applied row by row as application proceeds from eave to ridge.

The finished appearance of the hip/ridge/rake trim tile will vary significantly depending on where the roof side edge of the hip/ridge/rake trim tile rests on the field tile (high point or low point). Prior to installing tile, it is best to predetermine positioning of the field tile to the rake edge, with hip/ridge/rake trim tile, for the desired effect. It will be necessary to adjust the height of the nailer, cut off the right edge of the field tile, or leave a space between the field tile and the rake to achieve the desired appearance. For example; on a 6:12 slope, a 2x2 nailer, with approximately 3" cut off the right side of the adjoining field tile will position the cap tile to contact the field tile and the outer rake trim equally (see diagram). Slight spaces can be left between the field tile and the rake nailer to accommodate other slopes. Tile is applied right to left, so field tile adjoining the rake on the left side of the gable roof should be cut accordingly to achieve the same appearance. Always pre-check for the best fit.

When using Quarrix Universal Flashing, work from bottom to top, and overlap any rolls by 3" (7.62 cm). Like the bent metal flashings, Quarrix Universal Flashing only needs to lap the nailer or wooden rake trim about 1" (to the outside) and should not be visible when hip/ridge/rake trim pieces are applied.

Continued on page 22.

Boxed Rake

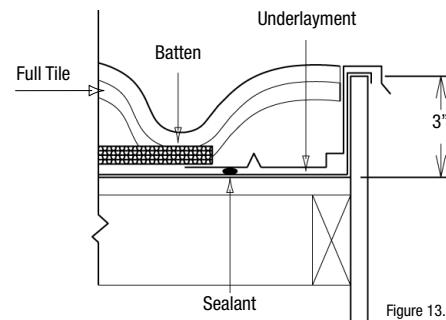

Figure 13. Boxed Rake

Capped Rake

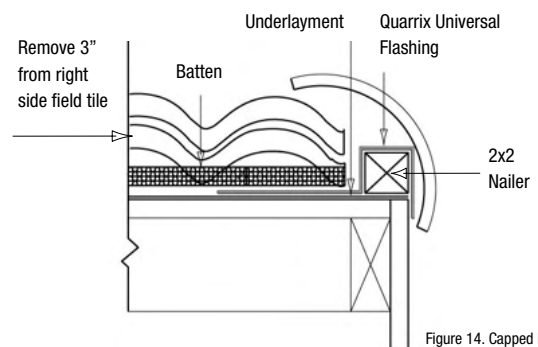

Figure 14. Capped Rake

Once all the field tile and Quarrix flashing is installed, the hip/ridge/rake tile can be applied to the rake. The first tile at the eave edge can either be a hip starter or a regular hip/ridge/rake tile depending on aesthetic preference. Cut the top of first hip/ridge/rake trim tile (or hip starter tile) so it is flush with the nose of the field tile. Butt successive hip/ridge/rake tile to the nose of each field tile. This will not match the exact field tile exposure up the rake, but it will result in the best cap fit to both the outside rake and the field tile. It is possible to match the exact exposure with other configurations, but large gaps between the caps and the field tile will have to be tolerated or packed with a roof mortar. Hip/ridge/rake tile should be secured with two Quarrix fasteners, or non-corrosive 3" ring shank nails, in the head lap area (concealed), to the rake nailer. Adhesive should be applied on the underside and top edge of the ridge trim to aid in wind resistance. If additional exposed fasteners are used on the outside rake, they should be caulked with a matching sealant.

NOTE: If rain gutters are desired on your roof, they can be installed prior to, or after tile installation. It is recommended that gutters be at least 6" wide to accommodate the rain dispersion created by the double roman profile.

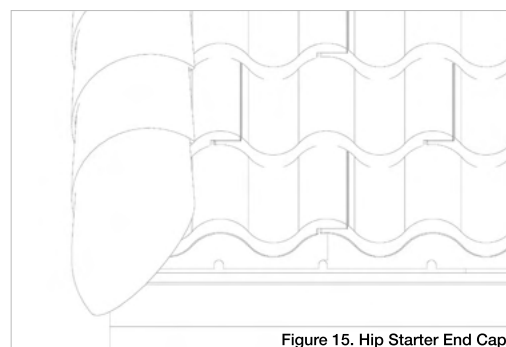

Figure 15. Hip Starter End Cap

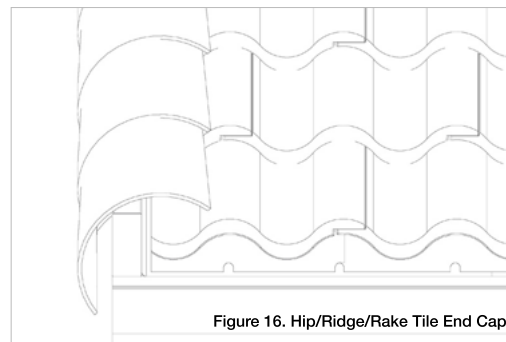

Figure 16. Hip/Ridge/Rake Tile End Cap

GENERAL MAINTENANCE

Algae/Moss

In some regions, the development of algae and moss can occur on any building material; the growth of moss or algae form on the dirt and moisture on the surface of the tile. Tile can easily be cleaned with water pressure, brushes and commercial roof cleaners.

Leaves and Other Debris

Keep tile free of all debris to help prevent any roof problems from arising, like water backup from damming in sensitive areas (valleys, skylights, penetrations, etc).

HIGH WIND INSTALLATIONS

Please contact Quarrix for information on installation methods for high-wind areas up to 110 mph. Similar construction methods apply, but with no more than a 13" exposure.. You may also contact Quarrix to request any potential amendment to Quarrix's Limited Warranty related to wind speeds. Quarrix will review each request on a case-by-case basis and any amendment will be made at Quarrix's sole discretion.

No person or entity is authorized by Quarrix to make, and Quarrix shall not be bound by, any statement or representation as to the performance of Quarrix Products other than what is contained in its Limited Warranty. No warranty shall be amended or altered except in a written instrument signed by Quarrix and Owner.

REPAIR

Replacing a Broken Tile Piece

Locate the broken tile piece, raise the butt end of the tile to the left of the broken one and insert a wedge to hold it up out of the way. Next, raise the butt end of the tile above to the right, and insert another wedge. If the broken tile was nailed, slide the flat bar between the tile and the deck/batten twisting it to loosen the nails. If the broken tile was screwed, break the water dam off at the top of the tile and cut through the fastener collar and screw with a hacksaw. Lift the broken tile up and to the right to remove. Apply a generous amount of construction adhesive to the underside of the new tile piece at the base of the lugs and on the top inch of the water lock. Slide the new tile up and to the left to interlock it with the one on each side. Remove the two wedges to complete replacing broken piece.

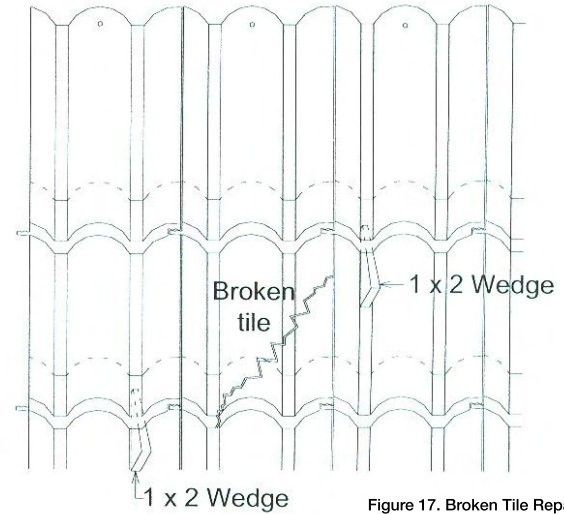

Figure 17. Broken Tile Repair

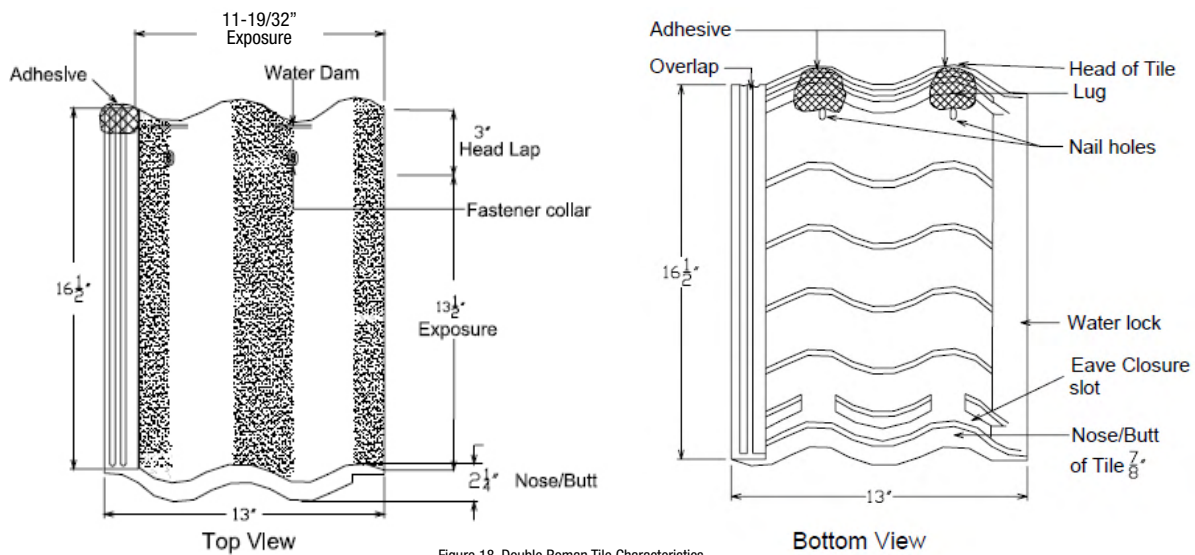

Figure 18. Double Roman Tile Characteristics

ARCHITECTURAL SPECIFICATIONS

Architectural specifications are available at Quarrix.com/Installation-Spec-Library and ARCAT.com.

APPENDIX A

NOTE: Quarrix does not manufacture the flashings listed in Appendix A; these are to be used as a reference when field fabricating.

Angle Flashing

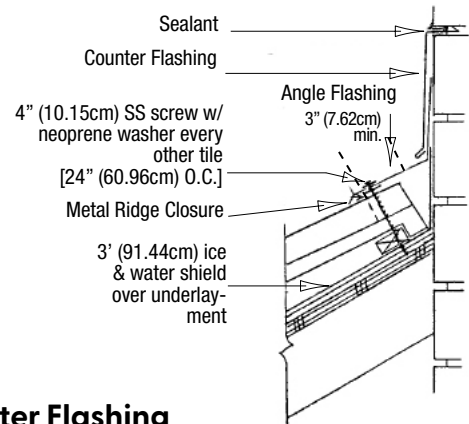
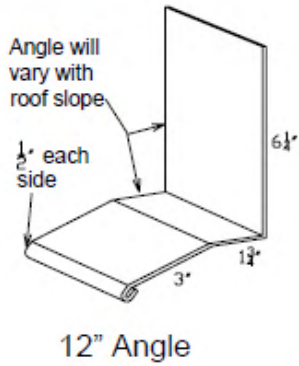
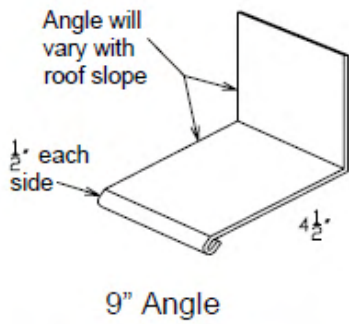

Bat Stop Flashing

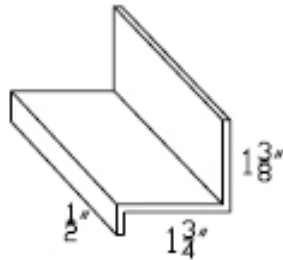

Counter Flashing

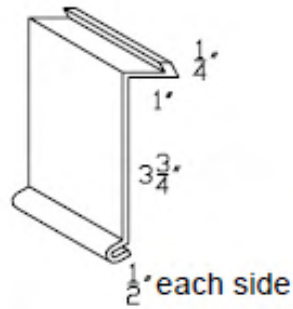

Stucco Counter Flashing

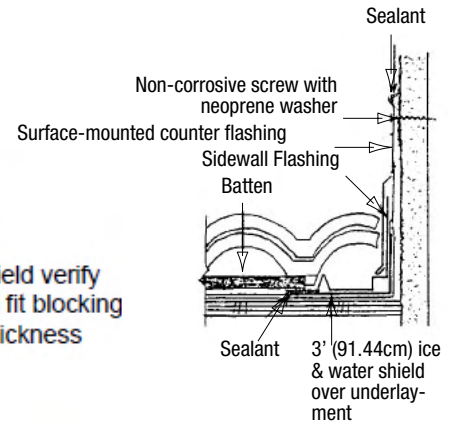
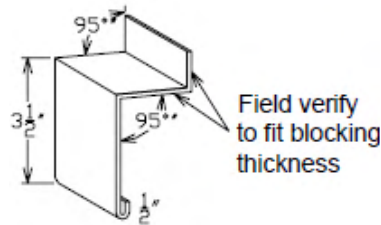
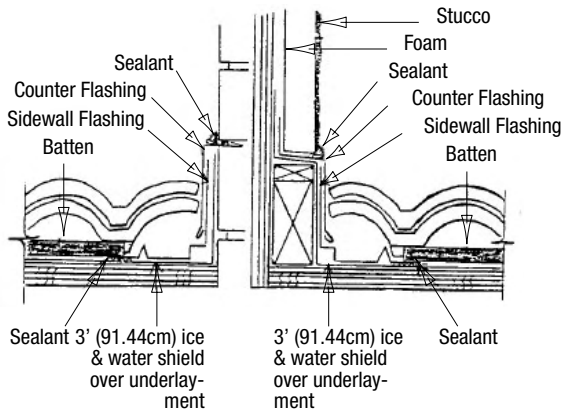

Eave Metal

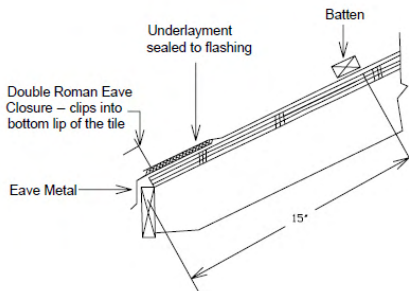
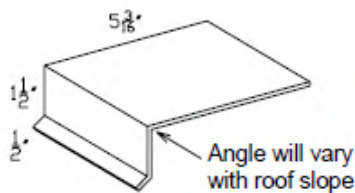

Gutter Eave Metal

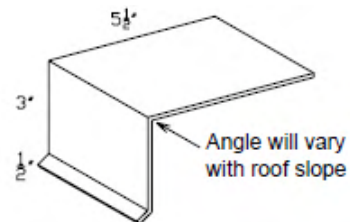

APPENDIX B

NOTE: Quarrix does not manufacture the flashings listed in Appendix B; these are to be used as a reference when field fabricating.

Flat Roof Eave Metal

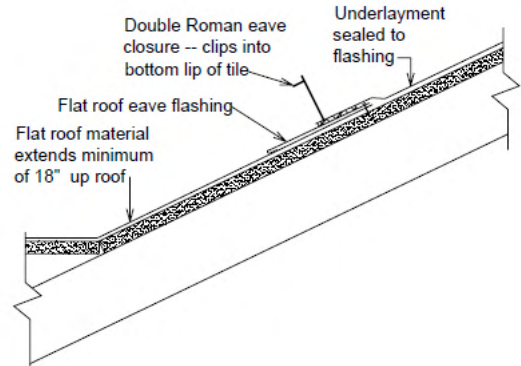
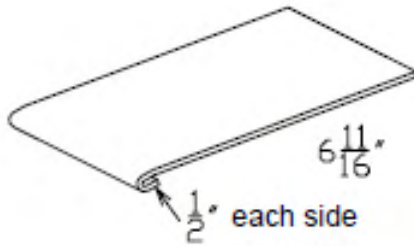

Gable Flashing

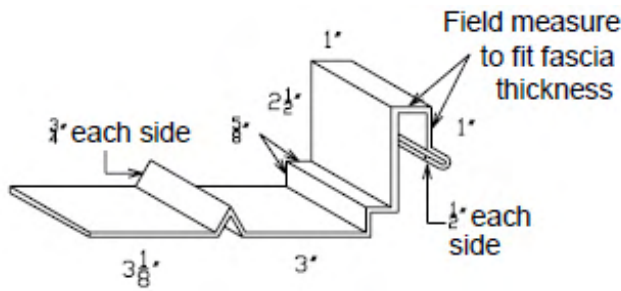

Flying Gable/Valley Flashing

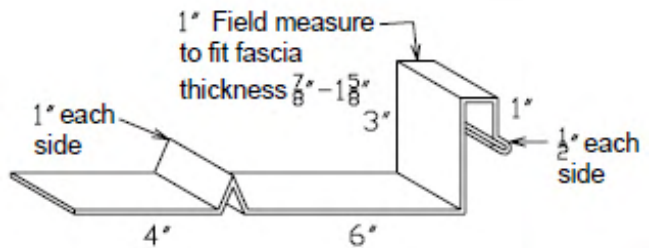

Hurricane Clip

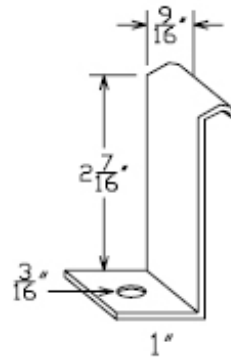

Hip Ridge Nailer

Height and angle will vary depending on roof slope

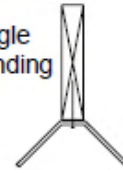

Half Saddle Open Valley Flashing

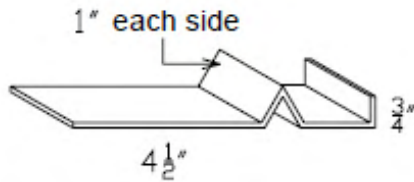

Side Saddle Channel Flashing

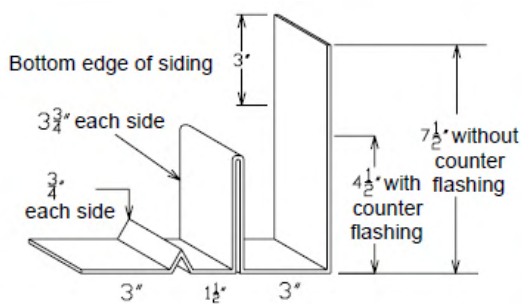

Side Wall Flashing

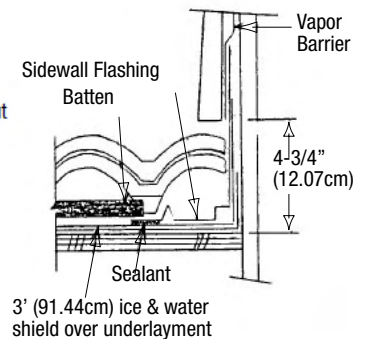
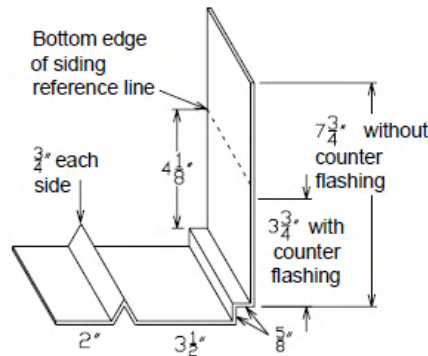

APPENDIX C

NOTE: Quarrix does not manufacture the flashings listed in Appendix C; these are to be used as a reference when field fabricating.

Closed Valley Flashing

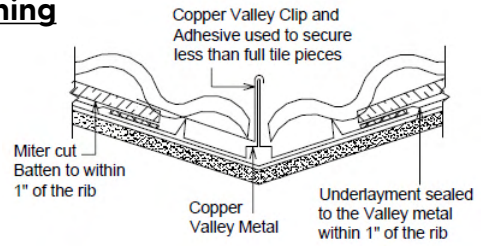
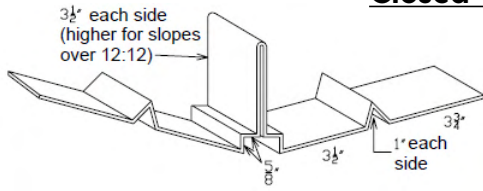

Open Valley Flashing

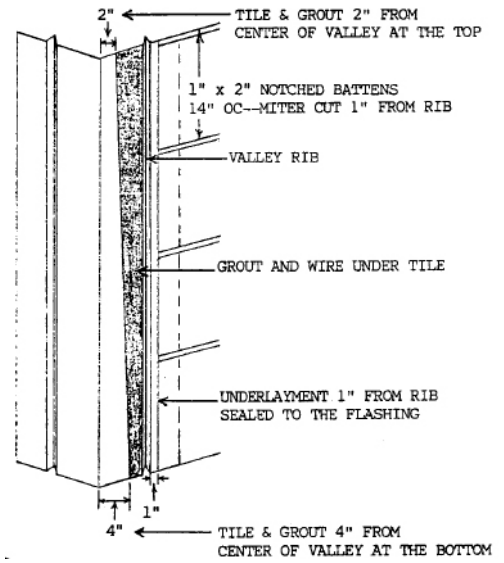
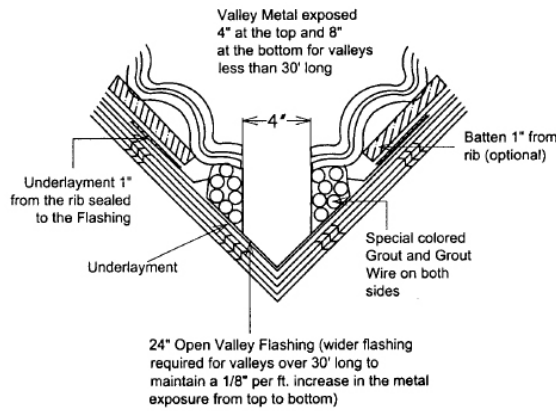
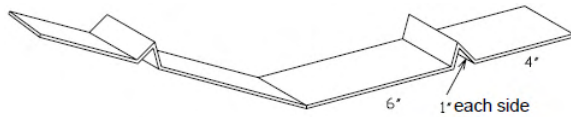

Dormer Flashing

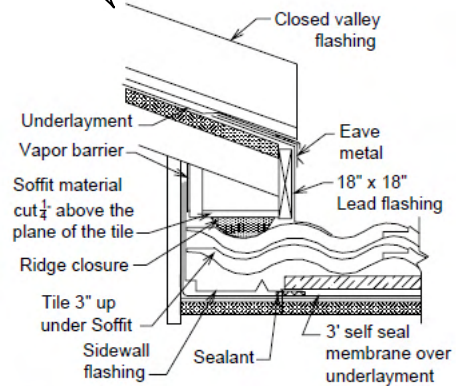
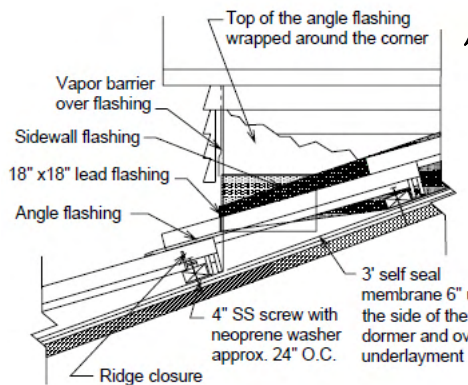
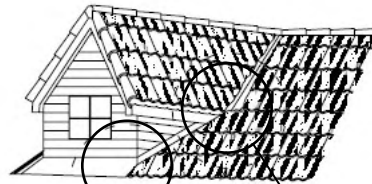

APPENDIX D

NOTE: Quarrix does not manufacture the flashings listed in Appendix D; these are to be used as a reference when field fabricating.

Chimney Flashing

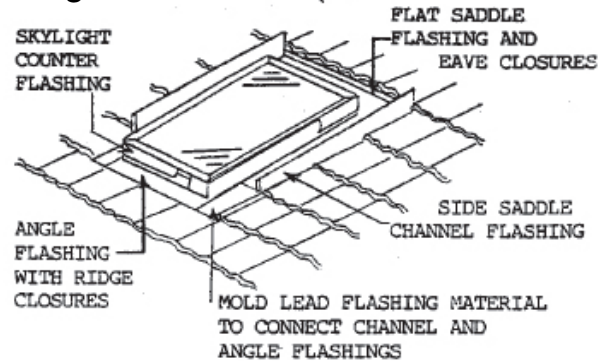
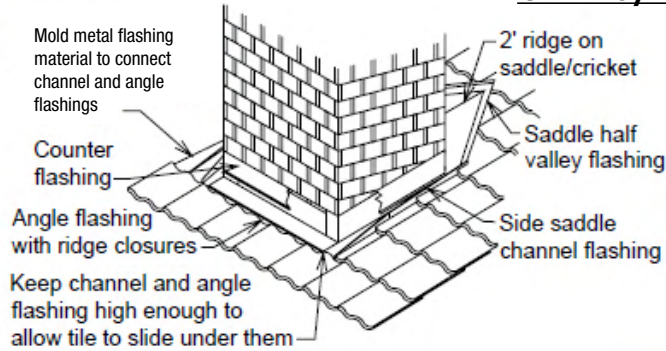

Cap Flashing at Flat Roof

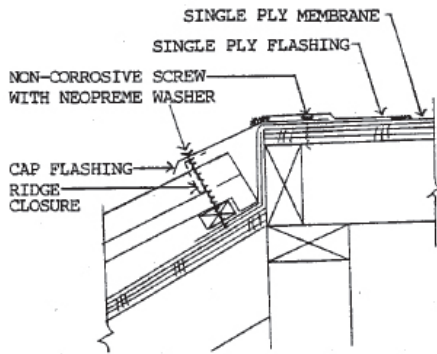

Ridge Trim & Vent at Top of Mansard

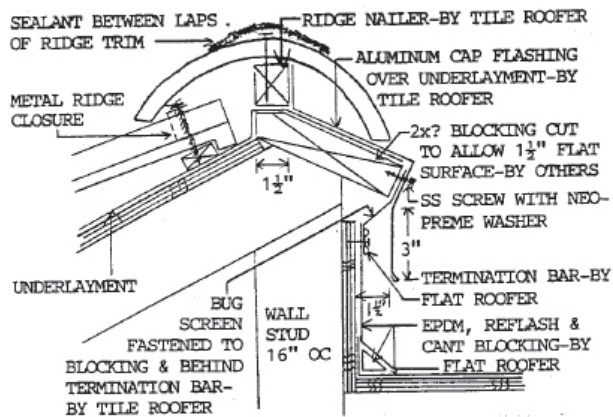

Quarrix Tile Blocking & Rake/Hip Trim

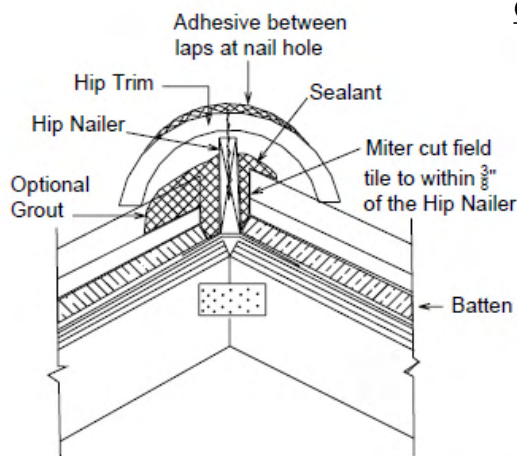

Gable Flashing WithOUT Rake Trim on Straight Gables

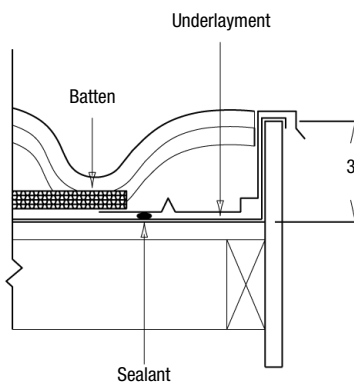

Gable Flashing WITH Rake Trim on Straight Gables

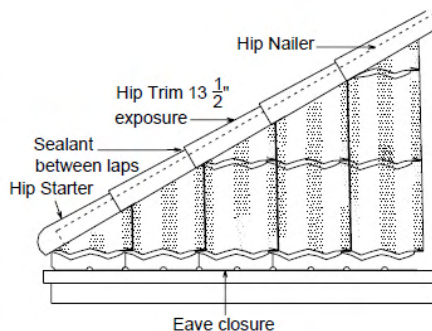
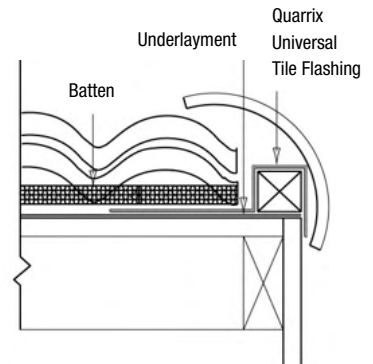

Miter cut Hip/ridge & Hip starter trim to fit. Add adhesive at the joint.

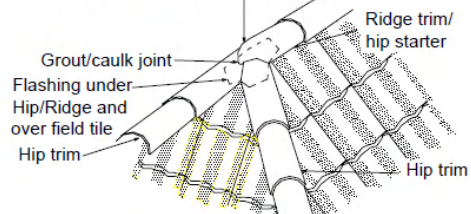

METRIC FIELD TILE CHARACTERISTICS

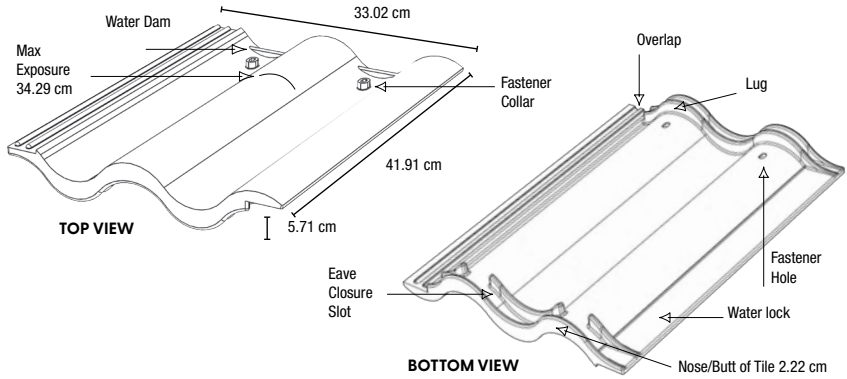

<p>OVERALL DIMENSIONS 33.02 cm x 41.91 cm x 5.715 cm</p> <p>MAXIMUM EXPOSURE 34.29 cm Height 29.448 cm Width</p>	<p>POUNDS PER SQUARE Class A - 134.716 kg Class C - 122.469 kg</p> <p>IMPACT RATING Class 4 (FM 4473)</p>	<p>BURNING BRAND Class A / Class C</p> <p>MATERIAL Polyethylene Polymer</p>	<p>SHIPPING INFORMATION Class A - 1.49 kg per piece Class C - 1.36 kg per piece 90 pieces per square 3 squares per pallet</p>
--	---	---	--

NOTE: Imperial measurements available on pg. 6 of Appendix.

METRIC HIP/RIDGE/RAKE TILE CHARACTERISTICS

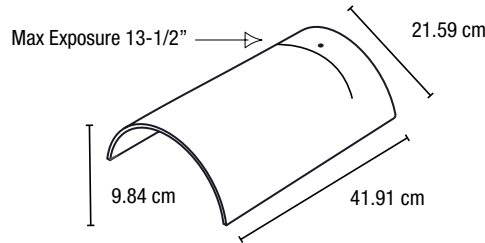

<p>OVERALL DIMENSIONS 21.59 cm x 41.91 cm x 9.84 cm</p> <p>MAXIMUM EXPOSURE 34.29 cm</p> <p>WEIGHT PER PIECE .907 kg</p>

NOTE: Imperial measurements available on pg. 6 of Appendix.

METRIC HIP STARTER TILE CHARACTERISTICS

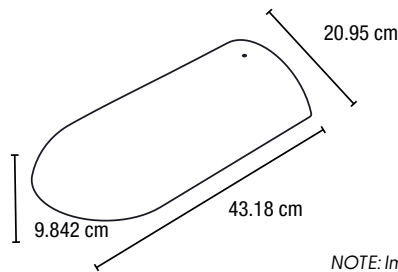

<p>OVERALL DIMENSIONS 20.95 cm x 43.18 cm x 9.84 cm</p> <p>MAXIMUM EXPOSURE 34.29 cm</p> <p>WEIGHT PER PIECE .861 kg</p>

NOTE: Imperial measurements available on pg. 6 of Appendix.

METRIC DRYROOF ROOF BATTEN CHARACTERISTICS

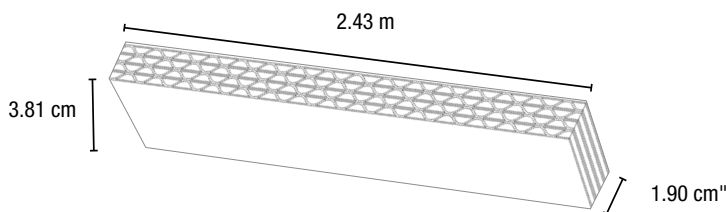

<p>OVERALL DIMENSIONS 2.43 m x 3.81 cm x 1.90cm</p> <p>NFA 5.6 sq. in/lin ft.</p> <p>MATERIAL HPDE Plastic</p>

NOTE: Imperial measurements available on pg. 6 of Appendix.

MEASUREMENTS

METRIC TILE DECK VENT CHARACTERISTICS

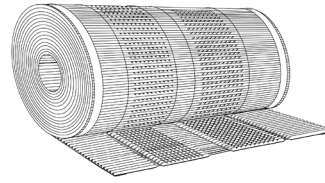

OVERALL DIMENSIONS

Black 38.1 cm x 7.62 m
 Terra Cotta 40 cm x 4.87 m
 Venetian Red 40 cm x 4.87 m
 Brown 40 cm x 4.87 m

NOTE: Imperial measurements available on pg. 7.

METRIC UNIVERSAL FLASHING CHARACTERISTICS

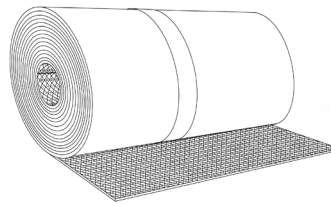

OVERALL DIMENSIONS

29.54 cm x 4.87 m

NOTE: Imperial measurements available on pg. 7.

METRIC UPPER METAL CLOSURE CHARACTERISTICS

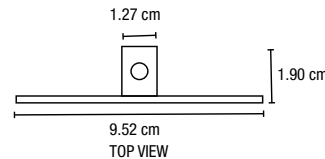
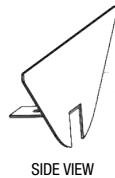

OVERALL DIMENSIONS

9.52 cm x 1.90 cm

NOTE: Imperial measurements available on pg. 7.

METRIC LOWER METAL EAVE CLOSURE CHARACTERISTICS

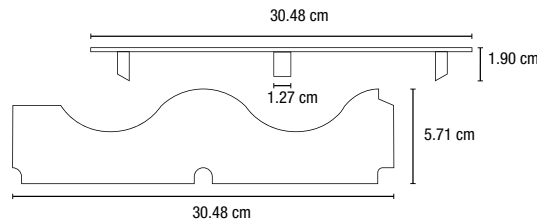
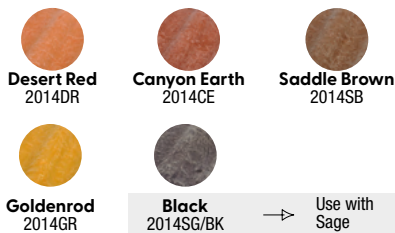

OVERALL DIMENSIONS

30.48 cm x 5.71 cm

NOTE: Imperial measurements available on pg. 7.

METRIC FASTENER CHARACTERISTICS

Phillips Drive
(No. 3)

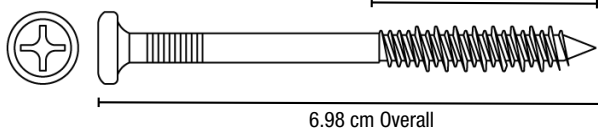

OVERALL DIMENSIONS

#10 x 6.98 cm

NOTE: Imperial measurements available on pg. 7.

LIMITED WARRANTY & CERTIFICATE OF WARRANTY

QUARRIX BUILDING PRODUCTS (“QUARRIX”), WARRANTS TO THE OWNER OF THE BUILDING AT THE TIME Composite Roof Tile (“Quarrix Products”) WERE ORIGINALLY INSTALLED (“Owner”), ONLY THAT the Quarrix Products will be free from manufacturing defects so as to not rot, split, splinter or suffer structural damage from normal weather conditions and termite or fungal decay when subject to normal use for a period of fifty (50) years from the date of original purchase or will not blow off or otherwise become damaged by winds less than one hundred and ten (110) miles per hour for a period of ten (10) years from the date of original purchase.

QUARRIX’S LIABILITY UNDER THIS WARRANTY IS LIMITED SOLELY TO REPLACEMENT OF DEFECTIVE QUARRIX PRODUCTS. OR, AT QUARRIX’S OPTION, REFUND OF ORIGINAL PURCHASE PRICE OR REASONABLE REPLACEMENT COST (as defined hereinafter). Owner’s sole and exclusive remedy for any claim whatsoever, whether in contract, warranty, tort, strict liability, or otherwise arising out of the use, storage or possession of Quarrix Products, including without limitation any claim that Quarrix Products failed to perform as warranted, shall be replacement with substitute Quarrix Products or refund of the original purchase price. To obtain replacement or refund, the Owner must have returned a copy of this certificate within thirty (30) days of installation and must submit a claim within thirty (30) days of the discovered defect together with this warranty certificate, the original purchase invoice indicating the date of purchase, pictures, a sample of the defective Quarrix Products, and a detailed description of the defect to Quarrix for settlement at Quarrix Building Products, 705 Pennsylvania Ave. S, Minneapolis, MN 55426.

THIS WARRANTY SHALL NOT APPLY TO QUARRIX PRODUCTS THAT HAVE NOT BEEN INSTALLED IN ACCORDANCE WITH MANUFACTURER’S GUIDELINES AND ALL APPLICABLE BUILDING OR SAFETY CODES OR HAVE NOT BEEN PAID IN FULL. This warranty does not provide protection against any failure, defect or damage caused by situations and events beyond Quarrix’s control, including but not limited to: (i) natural disasters, hail over 1.0” in diameter, fire, smoke, chemicals, earthquakes, lightning or static electricity, (ii) falling, thrown or blown objects, (iii) the neglect, abuse, misuse (including faulty installation, repair or maintenance), improper transportation, handling or storage of the Quarrix Products or other failure to comply with the instructions set forth in the documentation and/or manual accompanying the Quarrix Products, (iv) a modification of the Quarrix Products not provided by Quarrix, (v) a malfunction of any product not provided by Quarrix with which the Quarrix Products are used or combined, (vi) use, modification or other treatment of the Quarrix Products in a manner for which it was not designed or intended, (vii) defects or damage due to inferior building practices, ventilation, drainage issues or roof slopes inconsistent with snow and ice control, (viii) replacement under or subjection to abnormal use conditions, (ix) normal wear and tear including the natural effects of progressive aging on the color and surface of the tile, (x) discoloration and variations in color or uniformity caused by weathering and/or UV exposure, staining due to shade or sap, ash or proximity to metals that might cause discoloration; (xi) foot traffic, (xii) vandalism or other malicious actions, or (xiii) Quarrix Products blown off by winds in excess of 110 mph. This warranty does not cover product defects on installed roofs where such defects were apparent at or prior to installation.

After ten (10) years from the original purchase date, however, if Quarrix chooses to pay Reasonable Replacement Cost of the affected products, the amount Quarrix may pay will be reduced by the amount of usage the Owner has received of affected products. Thus, Quarrix will pay a percentage of the Original Purchase Price of the affected products. The percentage will be determined by dividing the number of months remaining in the warranty by 600 (the number of months in the original warranty period). This percentage will be multiplied times the ORIGINAL PURCHASE PRICE for the affected product. NOTE: Reasonable Replacement Costs covered by this Limited Warranty do not include costs to tear-off, dump fees, flashing, metal work, underlayment related work or related materials, or any labor associated with any replacement.

QUARRIX’S WARRANTY SHALL APPLY ONLY TO THE QUARRIX PRODUCTS. IN NO EVENT SHALL QUARRIX BE LIABLE FOR TRANSPORTATION, LABOR OR OTHER EXPENSES INCURRED BY THE OWNER, OR SPECIAL, INCIDENTAL, EXEMPLARY OR CONSEQUENTIAL DAMAGES OF ANY KIND WHATSOEVER, WHETHER BASED UPON

WARRANTY, CONTRACT, TORT, STRICT LIABILITY OR OTHERWISE. QUARRIX’S LIABILITY ARISING OUT OF THE MANUFACTURE, SALE OR SUPPLY OF THE QUARRIX PRODUCTS OR THEIR USE SHALL NOT EXCEED THE ACTUAL PURCHASE PRICE. THIS WARRANTY MAY BE TRANSFERRED ONE TIME TO NEW OWNER OF THE STRUCTURE WITHIN SEVEN (7) YEARS OF THE DATE OF ORIGINAL INSTALLATION. To do so, the original Owner must send a certified letter requesting the transfer, along with a photocopy of the original warranty or purchase contract, and provide the name, address and purchase date of the new Owner to Quarrix Building Products, 705 Pennsylvania Ave. S, Minneapolis, MN 55426, who will return a warranty to the new Owner.

OWNER IS SOLELY RESPONSIBLE FOR DETERMINING THE SUITABILITY OF USE OR APPLICATION OF ANY QUARRIX PRODUCT, OR WHETHER QUARRIX PRODUCTS MEET REQUIREMENTS OF APPLICABLE BUILDING CODES OR SAFETY CODES FOR SPECIFIC APPLICATIONS.

No person or entity is authorized by Quarrix to make, and Quarrix shall not be bound by, any statement or representation as to the performance of Quarrix Products other than what is contained in this warranty. This warranty shall not be amended or altered except in a written instrument signed by Quarrix and Owner.

THE FOREGOING WARRANTY IS EXCLUSIVE AND IN LIEU OF ANY OTHER WARRANTIES WITH RESPECT TO QUARRIX PRODUCTS, WHETHER ORAL OR WRITTEN, EXPRESS OR IMPLIED, INCLUDING WITHOUT LIMITATION, ANY IMPLIED WARRANTY OF MERCHANTABILITY, FITNESS FOR A PARTICULAR PURPOSE OR NON-INFRINGEMENT.

Laws from time to time in force in certain jurisdictions may imply warranties that cannot be excluded or can only be excluded to a limited extent. This warranty shall be read and constructed subject to any such statutory provisions. This warranty gives you specific legal rights. You may have other rights, which vary from state to state.



Quarrix®



Quarrix.com
800.438.2920

INST-DR02_050924